

An IoT based Healthcare for Remote Patient Monitoring System

Sanjay Balwani Asst. Professor JIT College of Engineering
Anil Bavaskar Asst. Professor JIT College of Engineering
Irfan Javed Student JIT College of Engineering
Sarfraaz Ali Lecturer GP Raghapur Supaul Bihar

Abstract-At present Health-care system has developed science and intelligence based on Wireless-Sensing nodes. Patients are confronting numerous issues because of the particular explanation of heart issues and assault due to nonexistence of good clinical upkeep to patients when they required. This is designed for monitoring the old patients and passing information to doctors and also loved ones. So by this innovative project we can reduce death rates by using Patient Health Monitoring that uses sensor technology and also internet connectivity to communicate with the loved ones in case of emergency. This system uses Temperature, heartbeat sensor, saline level indicator and accelerometer to track patient's health. Both the sensors are associated with the Arduino-UNO. So as to follow the patient wellbeing condition a miniature regulator is interfaced to a LCD show and Wi-Fi regulator to send the information to the web-worker (remote detecting hub). In case of any sudden changes in patient heart-rate or body temperature alert is sent about the patient using IOT. This system also shows patients heartbeat, temperature, saline level and acceleration tracked live data with timestamps over the Internet network. Thus Patient health monitoring system based on IOT uses internet to effectively monitor patient health and helps the user monitoring their loved ones and saves lives.

Key Words: IOT, LCD Display, Wi-Fi controller, server.

1. INTRODUCTION

Lately, remote innovation has expanded for the need of maintaining different divisions. As of late, IOT got a handle on most mechanical territories particularly mechanization and control. Biomedical is one of the ongoing patterns to give better medical care. In medical clinics as well as the individual wellbeing caring offices are opened by IOT innovation. So having shrewd framework different boundaries are seen that expands force, cost, and increment effectiveness. As indicated by this brilliant framework, this paper is explored. In conventional strategies, specialists assume a significant part in wellbeing registration. For this cycle requires a great deal of time for enrollment, arrangement and afterward registration. Likewise, reports are produced later. Because of this extensive cycle working individuals will in general disregard the exams or defer it. This cutting edge approach diminishes time utilization simultaneously. Medical scientists are trying in the field of innovation and research for many decades to get better health services and happiness in human lives.

The body temperature, heart rate, saline level, acceleration are prime parameters to monitor. This project gives temperature and heart rate values using IOT.

2. EXISTING SYSTEM

In a hospital, either the doctor or nurse has to move physically from one person to another for checking health condition, which may not be possible to monitor their health conditions continuously. Thus, any critical situations are not found easily unless the doctor or nurse checks the person's health at that moment. This may be a strain for the doctors who have to take care of many numbers of people in the hospital. Also, when medical emergencies happen to the patient, they are often unconscious and unable to indicate or press an Emergency Alert Button.

More than 50% of hospital deaths occur in patients who are not continuously monitored.

3. PROPOSED SYSTEM

In this proposed Patient monitoring system we use NodeMCU, two Arduino's and the respective sensors. These sensors used to monitor the different parameters of an ICU patient remotely and also control over medicine dosage is provided.

This system enables doctors to monitor vital parameters like body temperature, heart rate, acceleration and saline level of patients in remote areas of hospital as well as he can monitor the patient when he is out of the premises. If the parameters goes to abnormal these system sends alert Popup message to the doctors or it makes a buzzer sound. All these information and communication between doctor and patient is possible only through the website. NodeMCU is worked as server which takes the information gathered by Arduino's from sensors and puts complete information on the website created. This system gives the minute to minute update to the doctor. Thus, we can reduce the deaths and can save people more easily.

A. HARDWARE REQUIREMENTS:

- ARDUINO UNO
- Node MCU
- ACCELERATION SENSOR
- IR SENSOR
- HEART BEAT SENSOR
- TEMPERATURE SENSOR
- LCD DISPLAY

B. SOFTWARE REQUIREMENTS:

- Embedded C
- Arduino software

C. BLOCK DIAGRAM:

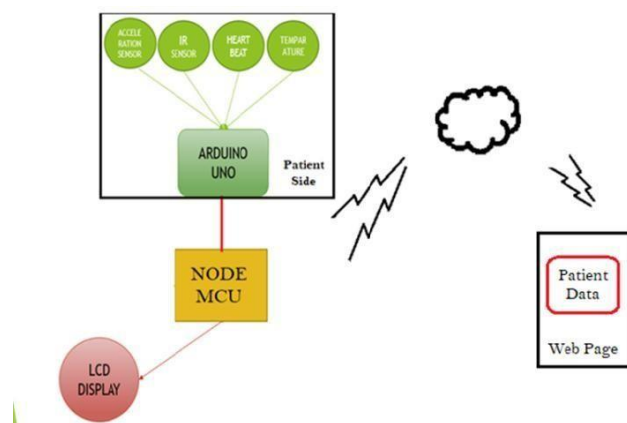

Fig. 1 Block diagram of Proposed system

D. COMPONENT DESCRIPTION:

i. **ARDUINO UNO:** It is a microcontroller board based on the ATmega328.

It has

14 digital I/O pins 6 analog pins

16 MHZ resonator A USB connection ICSP header
 Reset button

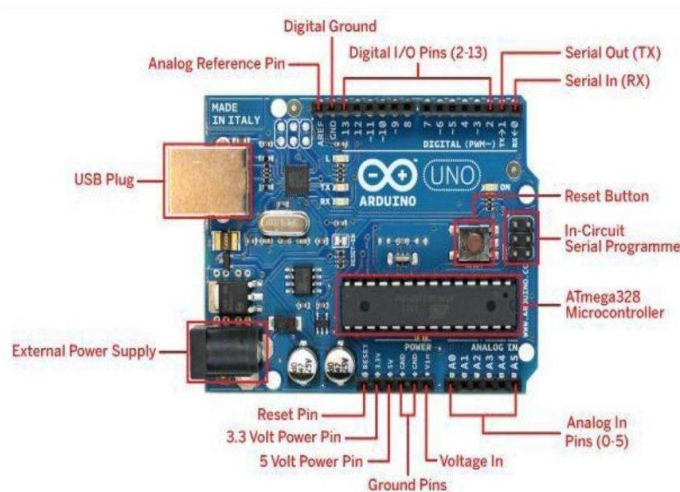

Fig. 2 Arduino UNO

- ii. **NODE MCU:** NodeMCU is an open-source based firmware and development board specially targeted for IOT based Applications. It includes firmware that runs on the ESP8266 Wi-Fi SOC from Espress if Systems, and hardware which is based on the ESP-12 module.

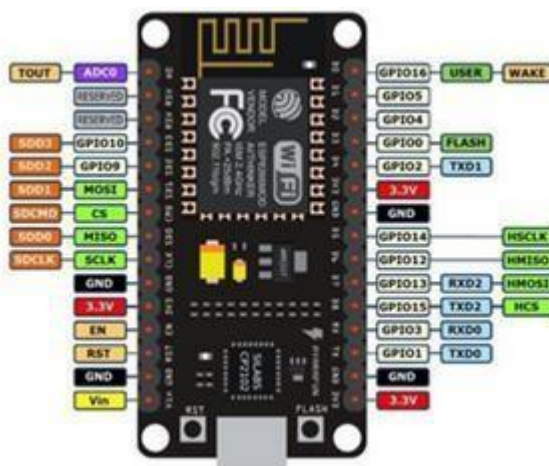

Fig. 3 Node MCU

- iii. **ACCELERATION SENSOR:** An accelerometer is an instrument that estimates appropriate increasing speed. Legitimate quickening is the increasing speed (the pace of progress of speed) of a body in its own prompt rest frame; this is not quite the same as facilitate speeding up, which is quickening in a fixed organize framework. For instance, an accelerometer very still on the outside of the Earth will gauge a quickening because of Earth's gravity, straight upwards (by meaning) of $g \approx 9.81 \text{ m/s}^2$. On the other hand, accelerometers in free fall (falling toward the focal point of the Earth at a pace of about 9.81 m/s^2) will gauge zero.



Fig. 4 P10 display module

- iv. **IR SENSOR:** IR locators are exceptionally separated for Infrared light; they are bad at recognizing noticeable light. Then again, photocells are acceptable at distinguishing yellow/green noticeable light, not great at IR light. IR finders have a demodulator inside that search for regulated IR at 38 KHz. simply sparkling an IR LED won't be recognized, it must be PWM flickering at 38KHz. Photocells don't have such a demodulator and can distinguish any recurrence (counting DC) inside the reaction speed of the photocell (which is about 1KHz).

IR detectors are digital out - either they detect 38KHz IR signal and output low (0V) or they do not detect any and output high (5V). Photocells act like resistors, the resistance changes depending on how much light they are exposed to



Fig. 5 IR Sensor

- v. **HEART BEAT SENSOR:** The heartbeat sensor depends on the rule of photograph plethysmography. It gauges the adjustment in volume of blood through any organ of the body which causes an adjustment in the light power through that organ (avascular locale). On account of utilizations where the heart beat rate is to be checked, the circumstance of the beats is more significant.

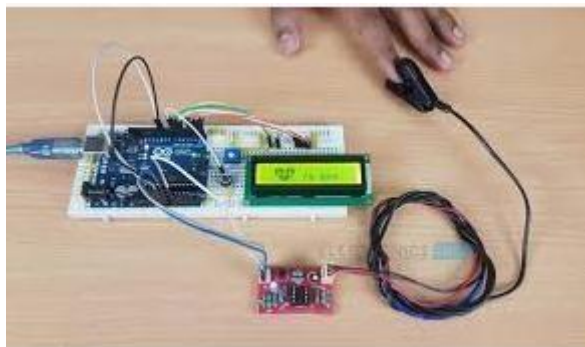

Fig. 6 Heart Beat Sensor interfacing with Arduino Uno

- vi. **TEMPERATURE SENSOR:** LM35 is a precision Integrated circuit Temperature sensor, whose yield voltage differs, in view of the temperature around it. It is a little and modest IC which can be utilized to quantify temperature anyplace between - 55°C to 150°C. It can without much of a stretch be interfaced with any Microcontroller that has ADC work or any advancement stage like Arduino.



Fig. 7 LM35 sensor

4. WORKING ALGORITHM

Step-1: The Heartbeat sensor is fixed to the patient's finger. This contains an IR sensor in it .Every pumping we get pulse from that sensor. This sensor output is given to the Arduino via Signal conditioning unit for amplification.

Step-2: LM35 is used as a temperature sensor. This temperature sensor output varies based on the temperature; this output is also given to Arduino.

Step-3: With the help of IR sensor we can measure saline level i.e. whether saline level crosses the threshold level or not and that information is passed to Arduino.

Step-4: Accelerometer is used to sense the acceleration of the patient body and if any abnormality is found that information is passed to arduino.

Step-5: The information collected from the sensors is processed by arduino and the processed data is passed to NODE MCU.

Step-6: NODE MCU is a WiFi module which collects the information from arduino and passes that information to server through internet connectivity.

Step-7: The information which is stored in the server can be viewed with the help of GUI(Graphical User Interface).

Step-8: The access to the GUI is given to doctor who can view the patient health status from remote location.



Fig. 8 Flow chart of Proposed system

5. ADVANTAGES

- Better patient experience
- Improved disease management
- Homecare
- Decreased costs
- Reduced Errors

6. APPLICATIONS

- Day-to-day activity monitoring applications
- Fall and movement detection applications
- Location tracking applications
- Medication intake monitoring applications

7. RESULTS

```
File Edit Sketch Tools Help
COM5
Send
heart beat= 78 BPM
temp_val=102 F
saline level = 1
patient position = 0
Autoscroll Show timestamp
Newline 9600 baud Clear output

const int InS5_pin = A
const int xpin = B3;
const int ypin = B2;
const int apin = B1;
const int hb = A4;
long run;
/* IM35 O/P pin */
int pushButton = 2;
int s=0;
void setup() {
  Serial.begin(9600);
  pinMode(pushButton,
}

void loop() {
  int x_adc_value, y_A
  double x_g_value, y_g_value, z_g_value;
```

Fig. 9 Simulation of proposed system on Arduino IDE

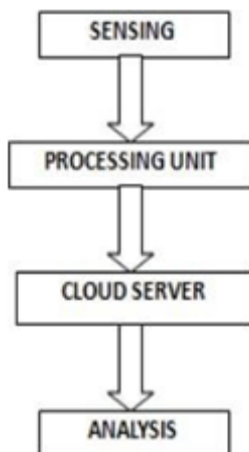

Fig. 10 Hardware showing sensors (heartbeat, IR, accelerometer, temperature sensor), controller board, Node MCU and display



Fig. 11 LCD display showing the initial message



Fig. 12 LCD display showing values sensed by sensors

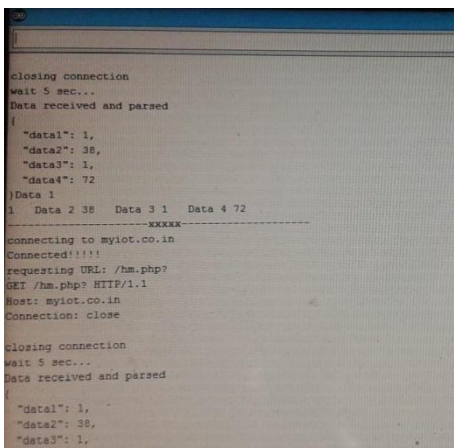

Fig. 13 Data received by NODE MCU and sent to server

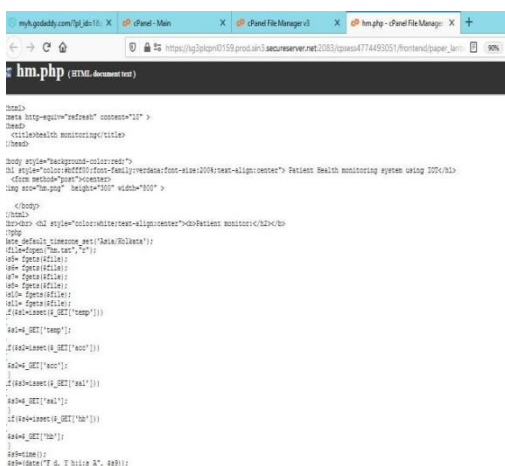

Fig. 14 Server side code of proposed system written in php and HTML



Fig. 15 Patient Health conditions data display in web browser

8. CONCLUSION & FUTURE WORK

The proposed system of patient health monitoring using IOT can be highly used in any emergency situations as it can be daily monitored, recorded and stored as a database. This system also enables doctor to monitor useful parameters like body temperature, heart rate, acceleration and saline level of patients in remote areas of hospital and also he can monitor patient when he is out of the premises. If any parameter goes to abnormal this system sends alert (Popup message) to the doctor so in future this IOT device can also be combined with the cloud computing so that the database can be shared in all hospitals for intensive care and treatment.

REFERENCES

1. Mirza Mansoor Baig & Hamid Gholamhosseini “Smart Health Monitoring Systems: An Overview of Design and Modeling”, Springer Science+Business Media New York 2013.
2. Vandana Milind Rohokale, Neeli Rashmi Prasad, Ramji Prasad, “A Cooperative Internet of Things (IoT) for Rural Healthcare Monitoring and Control”,978-1- 4577-0787-2/11/ ©2011 IEEE.
3. Alexandros Pantelopoulos, Nikolaos G. Bourbakis,” A Survey on Wearable Sensor-Based Systems for Health Monitoring and Prognosis”, Publisher: IEEE DOI: 10.1109/TSMCC.2009.2032660.
4. Home Based Health Monitoring System Using Android Smartphone, IJEE and Data Communication, Vol-2, Issue-2, Feb-2014, Sushama Pawar, P.W.Kulkarni
5. Li Da Xu,” A Survey Internet of Things in Industries”, IEEE Transactions on Industrial Informatics, Vol. 10, No.4, November 2014.
6. Ebrahim Al Alkeem¹, Dina Shehada¹, Chan Yeob Yeun¹,M. Jamal Zemerly,¹Jiankun Hu “New secure healthcare system using cloud of things”,Springer Science+Business Media New York 2017.