

Solar Panel Cleaning Robot Using Wireless Communication

Dr.K.S. Dhanalakshmi¹, S. Magesh Raj², K. Santhosh Kumar³, R. Keerthivash⁴

¹Assistant Professor, Department of Electronics and Communication Engineering, Kalasalingam Academy of Research and Education, Anand Nagar, Krishnankoil, India. E-mail: k.s.dhanalakshmi@klu.ac.in

²Student, Department of Electronics and Communication Engineering, Kalasalingam Academy of Research and Education, Anand Nagar, Krishnankoil, India. E-mail: rajmahesh71@gmail.com

³Student, Department of Electronics and Communication Engineering, Kalasalingam Academy of Research and Education, Anand Nagar, Krishnankoil, India. E-mail: ksanthoshkumar0077@gmail.com

⁴Student, Department of Electronics and Communication Engineering, Kalasalingam Academy of Research and Education, Anand Nagar, Krishnankoil, India. E-mail: keerthivash23@gmail.com

ABSTRACT

Solar energy is the most huge and extensive renewable energy sources. Solar panel is a cell which is converts sun UV radiation into electric energy. Recent decade of the years, solar panel usage will be drastically increased via in both commercial as well as industrial purposes. In large scale units of solar energy conversion, more number of solar panels is used. Mainly solar panel is placed in the outdoor or top of the buildings. Due to air pollution and direct communication with the outdoor and so it makes more dust particles. Due to these dust particles, it easily affects the throughput and yield of the electric energy production. In large scale industries should be necessary to clean the solar panel in a periodic manner. It is more tedious process to clean every panel and it consumes more time and man power. This proposed system contemporary to resolve the above limitation. It produces a remote control based robot and it's operated by our mobile phones. This arduino based automatic robot is interfaced with mobile phones through Bluetooth technology. It will be more compactable and reduce time as well as man power. It is highly efficient for the large scale solar panel units.

KEYWORDS

Solar Car, Solar Energy, Automatic Robot and Mobile Remote Control.

Introduction

Each and every year the need for electric energy is increasing tremendously. Generally, there are two types of sources of power generation, one is conventional source another one is non- conventional source [1-5]. Most conventional sources like thermal power, nuclear power are commercially used to generate the electric power but those power plants result in emission of unwanted gas into the atmosphere and create many problems for both the environment and people. But, in non-conventional methods like solar energy, wind energy, tidal energy, hydel energy is eco-friendly, in which solar power generation is an effective and also has cost benefit [6-11].

In current worlds condition goes towards most energy scarcity in after the one or two decades. In recent days the government is strictly avoid the carbon dioxide emitting energy sources [12-19]. The evolution of renewable energy is built in different kinds. Most of the governments are taking action to improve and implant the renewable energy sources. Here, the solar renewable energy act a major role by via solar panel scales [20-27].

In solar panel, some constraints affect the throughput such as dust, humidity and wrong tilt. In automated solar PV panels rotation ut of the solar PV panels cleaning aims into the automation is widely used to reduce the barriers against the maximum throughput as well as efficiency. This paper reveals all the direct and indirect constraints which will affect the efficacy in automated solar energy generation system [28-36]. Here, it deeply explains the hurdles in cleaning the solar panels by automatically.

The various natural aspects are like temperature, poor solar light, solar irradiance which all the above aspects harshly affect the efficiency of the solar panel [37-41]. When the solar panel affects by over the temperature, which makes the solar panels into short circuit and it decreases the throughput of solar energy generation [42-51].

Related Works

The innovative idea for this solar car based cleaning is modified into fully computerized [52-59]. It will help to reduce the human involvement and avoid dust allergy and other dust based diseases [60-67]. The dark water cleaning procedure forestalls bother pervasions by lessening the deposits that can draw in and bolster bugs [68-74]. It likewise improves the time span of usability and tactile nature of nourishment items. In the proposed framework, the machine is worked with remote control to clean the sewage. Henceforth, this framework stays away from the effects from the sewage squander furthermore, its unsafe gases [75-79].

In the mode of automation, sun light with the angle of projection is also major factor for the efficiency and throughput of the solar panels. Exact position and tilt angle of the panel is minus 10 degrees. Some of the atmospheric moistures and dust deposition on the solar panel makes great impact on the solar energy generation. When, the intensity of the dust deposition is inversely proportional to the solar panel efficiency [80-82].

This paper highlights architecture of the automatic cleaning panels with the help of robots. The principle of working in automatic cooling has done with the help of highly rhythmic pressure dumberd with the robot. It clears all the harmful and harmless dust particles and debris. With the help of high stream of water removes all the solar panels in order with the left and right conditioned motors.

The main motto of this proposed automotive idea focused to eliminate the human involvements and it is most useful for the high risk works such as drainage cleaning. The black water cleaning process helps to prevent pest infestations by reducing the residues that can attract and support pests. It also improves the shelf life and sensory quality of food products.

Ultrasonic Sensor

Sensor which is used to sense any object or things presents in a unit meter distance. It makes the automatic robot into selfless movement and collision avoidance. It clears the component and more efficient in a bounded region of movement. This sensor is mainly purposeful for the own decision making and reliable. It majorly used as a component of security and self-decision making system.



Fig. 1. Ultrasonic sensor snapshot

An ultrasound waves generated by the ultrasonic sensor, is used to find object or walls for collision avoidance. it evolves a ultrasound waves in a specific frequency, it hits the target and reflected. It is received by the receiver present in the ultrasonic sensor. The distance between the object is observed by the elapse time between wave reflections and receive. It is shown in fig.1.

Dc Motor

Automation is a term represents movement of device using without human operations. In this evolution of automation, electric motors play a major role. Electric motor is a device converts electrical energy into mechanical action. It observes a electric energy and rotates the rotor in a flexible angle of motion to the user preferable. Electric engines are extensively arranged into two distinct classes: Direct Current (DC) engine and Alternating Current (AC) engine. In this article we will examine about the DC engine and its working. And furthermore how a stuff DC engines functions. A DC engine is an electric engine that sudden spikes in demand for direct flow power. In any electric engine, activity is subject to basic electromagnetism. In these DC engine A current conveying conductor creates an attractive field, when this is then positioned in an outer attractive field, it will experience a power corresponding to the current in the conductor and to the strength of the outside attractive field. It is a gadget which changes electrical energy over to mechanical energy. It chips away at the way that a current conveying conductor set in an attractive field encounters a power which makes it turn regarding its unique position. It is figured in fig.2.



Fig. 2. DC Motor

Bluetooth Module



Fig. 3. Bluetooth Module

HC-05 Bluetooth Module is an easy to use Bluetooth SPP (Serial Port Protocol) module, designed for transparent wireless serial connection setup. Its communication is via serial communication which makes an easy way to interface with controller or PC. HC-05 Bluetooth module provides switching mode between master and slave mode which means it able to use neither receiving nor transmitting data. It is also figured in fig.3.

Existing System

Conventional robot manipulators are heavy, and poor in accessing congested spaces due to the constraints imposed by their rigid links. Their utilization regularly depends on the extra sending of sensor heads, which can be massive, and furthermore hard to send in restricted spaces. We present a novel, light, constantly bowing "tree-like" robot with retractable branches. We show its capacity for special and versatile tasks over different scales and talk about the potential for utilization of such robots in activities in Space. The robot configuration considered in this highlights agreeable consistent spine components, and is subsequently an illustration of a continuum robot. The sub-field of advanced mechanics zeroing in on continuum "trunk and limb" robots has seen a flood of interest and action lately, empowering various new and imaginative applications, especially in operations. Continuum robots have been proposed for Space applications already. NASA fostered the first long, slim "ring" continuum robot, fully intent on infiltrating and investigating blocked spaces infeasible with ordinary unbending connection based automated constructions. Later endeavors have refined the ring configuration, focusing on investigation procedure on the International Space Station. The vital development in the robot configuration talked about here is in its equal and variable geography structure. Two sets of autonomously controlled "branches" can be stretched out from the focal "trunk" (consequently the abbreviation TREE, from Tree Robot for Extended Environments). This gives the capacity to design from a solitary trunk (with the branches completely withdrawn) to a wide assortment of equal geographies. This permits the robot to enter and move inside restricted spaces, and afterward arrange to introduce different sensor sees and additionally controllers to its current circumstance. The benefits of such equal mechanical designs in Space conditions have been shown beforehand, eminently in the multi (unbending connection)-limbed Dextre robot. In any case, the utilization of equal continuum structures is new, and can give novel usefulness, as talked about in this task.

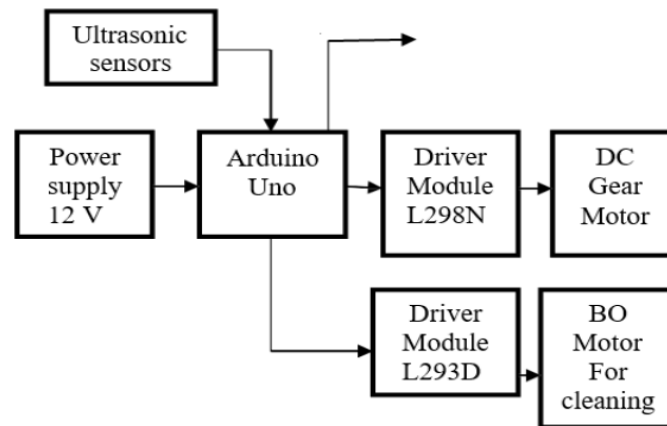

Fig. 4. Block Diagram of Solar Panel Cleaning Robot Using Wireless Communication

Proposed System

Settled dust particles deposited on the solar panel and its affects throughput of the solar energy conversion. This proposed solar car acts like an autonomous robot and which is generally clean every throughput hazardous particles using Bluetooth based technology. When solar car is buildup with arduino microcontroller and which is biased with the mobile phone via Bluetooth. Solar car movements happen with the help of couple of ultrasonic sensors. The solar car is placed top of the solar panel at the time of cleaning. It acts like a semi-autonomous robot moved with the help ultrasonic sensor in a structured angle. Mobile based controller sets a forward and reverse mode of operation. During this operation, BO motor turns on and the brushes cleaned the solar panel. The cleaning of the dust and hazardous particles removed in a high efficient manner. The entire performance was illustrated as a block diagram in fig.4.

Result and Discussion

The Bluetooth biased Arduino microcontroller was interfaced with consistent and efficient ultrasonic sensors. These ultrasonic sensors moved with the help of general power supply unit. The action of forward and reverse direction is handled by the human with the help of mobile phones. It cleans the system in a periodic action of time and its set us by the users. Ultrasonic sensor produces an ultrasound waves in an opposite direction with the mutual. The smartness

or innovation was performed with the automatic motor on and off with the help of dust removed conditions. It encourages the solar energy production in a smarter way of approaches. The efficient proposed solar robot car was implemented and its corresponding output is shown in fig.5.

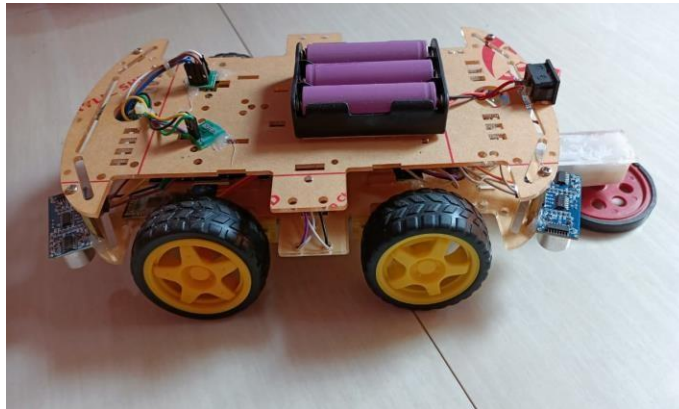

Fig. 5. Hardware result of solar panel cleaning robot

Conclusion

In this photovoltaic modules perform decried ideal and optimum throughputs. Nature defined hazards are the major causes of the photovoltaic performance. This proposed system climaxes the effect of dust, dirt, pollution, sea salt on the PV systems efficiency. With rising implementation of photovoltaic arrays, a new method of cleaning and inspection is necessary. A reliable, cost-effective, remote controlling and automatic PV cleaning robot is designed and implemented. Its main purpose is to clean solar panels from dust. This proposed system is used to resolve in an efficient manner and increases the performance of the PV system increases. This automatic dust cleaner will overcome some of the demerits of the existing system and will bring revolution in today's conditions. It is made up of rotating cylindrical brush to scrub the photovoltaic panels to remove the dirt and direct it away from the panels. The cleaning head is designed to clean while traveling both upwards and downward. The device developed significantly reduces the number of workers needed to clean arrays using limited resources and taking less time. As for now, in order to turn off the robot, the user has to place the ultrasonic sensors in all corners of the robot which detects the edge of the panel and shutdown automatically.

References

- [1] Nasib Khadka, Binamra Adhikari, Aayush Bista & Ashish Shrestha, "Solar Panel Cleaner Technology: A Review", *International Conference on Developments in Renewable Energy Technology (ICDRET)*, April-2018
- [2] Mohammad A. Jaradat, Mohammad Tauseef, Yousuf Altaf, Roba Saab, Hussam Adel, Nadeem Yousuf, & Yousef H. Zurigat, "A Fully Portable Robot System for Cleaning Solar Panels", *International Symposium on Mechatronics and its Applications (ISMA)*, December- 2015
- [3] Mohammad Reza Maghami, Hashim Hizam, Chandima Gomes, Mohd Amran Radzi, Mohammad Ismael Rezaadad, Shahrooz Hajighorbani, "Power loss due to soiling on solar panel: A review," *Renewable and Sustainable Energy Reviews*, 2016.
- [4] Nurhasliza Hashim, M.N. Mohammed, Rubendren A/L Selvarajan, Salah Al-Zubaidi, Samaher Mohammed, "Study on Solar Panel Cleaning Robot", *IEEE International Conference on Automatic Control and Intelligent Systems*, 2019.
- [5] Thanapon Sorndach, Noppadol Pudchuen & Pornsak Srisungsitthisunti, "Rooftop Solar Panel Cleaning Robot Using Omni Wheels", *Advances in Science and Engineering Technology International Conferences (ASET)*, July- 2018

- [6] Prof. Ketan V. Dhande, "Design and fabrication of river cleaning system", *International Journal of Modern trends in Engineering and Research* 'Volume 4, Issue 2 [February- 2017], ISSN(PRINT): 2393-8161.
- [7] Prof. Ajay Dhumal, "Study of river harvesting and trash cleaning machine" *International Journal of Innovative Research in Science and Engineering*, Volume 2, Issue 3 [March-2016] ISSN: 2454-9665.
- [8] Ndubuisi c. Daniels, "Drainage System Cleaner A Solution to Environmental Hazards", *IRJES*, Volume 3, Issue 3(March 2014)
- [9] Osiany Nurlansa, Dewi Anisa Istiqomah, and Mahendra Astu Sanggha Pawitra, "AGATOR (Automatic Garbage Collector) as Automatic Garbage Collector Robot Model" *International Journal of Future Computer and Communication*, Vol. 3, No. 5, October 2014.
- [10] Basant Rai, "Pollution and Conservation of ganga river in modern India", *International Journal of Scientific and Research Publications*, Volume 3, Issue 4, April 2013 1 ISSN 2250-315
- [11] Huang Cheng, Zhang Zhi, "Identification of the Most Efficient Methods for Improving Water Quality in Rapid Urbanized Area Using the MIKE 11 Modeling System", 2015 *Seventh International Conference on Measuring Technology and Mechatronics Automation*.
- [12] Emaad Mohamed H. Zahugi, Mohamed M, Shanta and T. V. Prasad, "Design of Multi-Robot System for Cleaning Up Marine Oil Spill", *IJAIT* Vol. 2, No.4, August 2012.
- [13] Prof. N.G. Jogi, Akash Dambhare, Kundan Golekar, Akshay Giri, Shubham Take, "Efficient Lake Garbage Collector by Using Pedal Operated Boat", *IJRTER* Volume 02, Issue 04; April 2016 ISSN: 2455-1457.
- [14] Ankita B.Padwal, Monica S. Tambe, Pooja S. Chavare, Reshma K. Manahawar, Mitali S. Mhatre, "Review Paper on Fabrication Of Manually Controlled Drainage Cleaning System", *IJSER*, Volume 8, Issue 3, March-2017 ISSN 2229-5518
- [15] Dabhi Chirag, Gandhi Mayank and et al, 2017. Design And Development of Solar Panel Cleaning Machine, *International Journal of Advance Engineering and Research Development* 2017.
- [16] Kadam Bhagwat, Manchewar Gajanan and et al, 2017. Artificial Intelligence Solar Panel Cleaning Mechanism, *Ijariie* 3, pp. 2299-2303.
- [17] U. Zulfiqar, S. Mohy-Ul-Din, A. Abu-Rumman, A.E.M. Al-Shraah, and I. Ahmed, "Insurance-Growth Nexus: Aggregation and Disaggregation," *The Journal of Asian Finance, Economics and Business*, vol. 7, no. 12, pp. 665–675, Dec. 2020. <https://doi.org/10.13106/jafeb.2020.vol7.no12.665>
- [18] Al-Shqairat, Z.I., Al Shraah, A.E.M., Abu-Rumman, A., "The role of critical success factors of knowledge stations in the development of local communities in Jordan: A managerial perspective," *Journal of management Information and Decision Sciences*, vol. 23, no.5, pp. 510-526, Dec. 2020. DOI: 1532-5806-23-5-218
- [19] Ahmed Eltweri, The forthcoming chapter of accountancy using Blockchain, *The International EFAL-IT BLOG Information Technology innovations in Economics, Finance, Accounting, and Law*, Volume 1 – Issue 7/2020 – Bacau (Romania).
- [20] Caterina De Lucia, Luigi Pio Leonardo Cavaliere, Ester Salvato, Alessio Faccia, Growth Effects of Remittance: A Case of Turkey Diaspora, *Psychology and Education Journal*, 2021, Volume 58, Number 1, pages 690-698, DOI: <https://doi.org/10.17762/pae.v58i1.819>
- [21] D.S. Hooda, Keerti Upadhyay and D.K. Sharma, "On Parametric Generalization of 'Useful' R-norm Information Measure" *British Journal of Mathematics & Computer Science*, Vol. 8(1), pp. 1-15, 2015.
- [22] Narcisa Roxana Moşteanu, Financial investments' challenges in 2020–time for education and professional development, *The International EFAL-IT BLOG Information Technology innovations in Economics, Finance, Accounting, and Law*, Volume 1 – Issue 7/2020 – Bacau (Romania).
- [23] D.S. Hooda, Keerti Upadhyay and D.K. Sharma, "A Generalized Measure of 'Useful R-norm Information'", *International Journal of Engineering Mathematics and Computer Sciences*, Vol 3(5), pp.1-11, 2014.

- [24] Luigi Pio Leonardo Cavaliere, Julián Andrés Díaz Tautiva, Camila Barragán, Saad Uddin Khan, Analyzing The Pattern And Relative Importance Of Remittance Sources Of Pakistan, *International Journal of Management (IJM)*, Volume 12, Issue 1, January 2021, pp.879-888, DOI:10.34218/IJM.12.1.2021.078
- [25] D.S. Hooda, Keerti Upadhyay and D.K. Sharma, "Bounds on Cost Measures in terms of 'Useful' R-norm Information Measures" *Direct Research Journal of Engineering and Information Technology*, Vol.2 (2), pp.11-17, 2014.
- [26] Snehal Y. Hole, Luigi Pio Leonardo Cavaliere, Caterina De Lucia, India's Coastline Can Become an Engine of Growth: *An Economic Overview, Psychology and Education Journal*, 2021, Volume 58, Number 1, pages 2158-2167, DOI: <https://doi.org/10.17762/pae.v58i1.1093>
- [27] D.S. Hooda and D.K. Sharma, "Lower and Upper Bounds Inequality of a Generalized 'Useful' Mean Code Length" *GAMS Journal of Mathematics and Mathematical Biosciences*, Vol. 4(1), pp.62-69, 2013.
- [28] S.K. Khan et al., "UAV-aided 5G Network in Suburban, Urban, Dense Urban, and High-rise Urban Environments," in 2020 IEEE 19th *International Symposium on Network Computing and Applications (NCA)*, 2020, pp. 1-4: IEEE.
- [29] D.S. Hooda, Keerti Upadhyay and D.K. Sharma, 'Useful' R-Norm Information Measure and its Properties" *IOSR Journal of Electronics and Communication Engineering*, Vol. 8, pp. 52-57, 2013.
- [30] S.K. Khan, U. Naseem, H. Siraj, I. Razzak, and M.J.I.W.C. Imran, "The role of unmanned aerial vehicles and mmWave in 5G: Recent advances and challenges," *Transactions on Emerging Telecommunications Technologies*, p. e4241.
- [31] Pandya, S.; Ambient Acoustic Event Assistive Framework for Identification, Detection, and Recognition of Unknown Acoustic Events of a Residence, *Advanced Engineering Informatics*. Elsevier. <http://www.sciencedirect.com/science/article/pii/S147403462030207X>
- [32] D.S. Hooda, Sonali Saxena and D.K. Sharma, "A Generalized R-Norm Entropy and Coding Theorem" *International Journal of Mathematical Sciences and Engineering Applications*, Vol.5 (2), 385-393, 2011.
- [33] Ghayvat, H.; Pandya, S.; Awais, M. Recognizing Suspect and Predicting the Spread of Contagion Based on Mobile Phone Location Data (COUNTERACT): A System of identifying COVID-19 infectious and hazardous sites, detecting disease outbreaks based on internet of things, edge computing and artificial intelligence, Sustainable Cities and Society
- [34] D.S. Hooda and D.K. Sharma, "Bounds on Two Generalized Cost Measures" *Journal of Combinatorics, Information & System Sciences*, Vol. 35(3-4), pp. 513-530, 2010.
- [35] Pandya S, Wakchaure MA, Shankar R, Annam JR. Analysis of NOMA-OFDM 5G wireless system using deep neural network. *The Journal of Defense Modeling and Simulation*. 2021. doi:10.1177/1548512921999108 (as First author). Awais, M.; Ghayvat, H.; Krishna
- [36] Pandarathodiyil, A.; Nabillah Ghani, W.M.; Ramanathan, A.; Pandya, S.; Walter, N.; Saad, M.N.; Zain, R.B.; Faye, I. Healthcare Professional in the Loop (HPIL): Classification of Standard and Oral Cancer-Causing Anomalous Regions of Oral Cavity Using Textural Analysis Technique in Autofluorescence Imaging. *Sensors*, 2020, 20, 5780. <https://doi.org/10.3390/s20205780>
- [37] D.K. Sharma and D.S. Hooda, "Generalized Measures of 'Useful' Relative Information and Inequalities" *Journal of Engineering, Management & Pharmaceutical Sciences*, Vol.1(1), pp.15-21, 2010.
- [38] Patel, C.I.; Labana, D.; Pandya, S.; Modi, K.; Ghayvat, H.; Awais, M. Histogram of Oriented Gradient-Based Fusion of Features for Human Action Recognition in Action Video Sequences. *Sensors* 2020, 20, 7299. <https://doi.org/10.3390/s20247299>
- [39] Ghayvat, H.; Awais, M.; Pandya, S.; Ren, H.; Akbarzadeh, S.; Chandra Mukhopadhyay, S.; Chen, C.; Gope, P.; Chouhan, A.; Chen, W. Smart Aging System: Uncovering the Hidden Wellness Parameter for Well-Being Monitoring and Anomaly Detection. *Sensors* 2019, 19, 766. <https://doi.org/10.3390/s19040766>.

- [40] D.S. Hooda and D.K. Sharma (2010) "Exponential Survival Entropies and Their Properties" *Advances in Mathematical Sciences and Applications*, Vol. 20, pp. 265-279, 2010.
- [41] Barot, V., Kapadia, V., & Pandya, S., QoS Enabled IoT Based Low Cost Air Quality Monitoring System with Power Consumption Optimization, *Cybernetics and Information Technologies*, 2020, 20(2), 122-140. doi: <https://doi.org/10.2478/cait-2020-0021>.
- [42] D.S. Hooda and D.K. Sharma, "Generalized 'Useful' Information Generating Functions" *Journal of Appl. Math. and Informatics*, Vol. 27(3-4), pp. 591-601, 2009.
- [43] Sur, A., Sah, R., Pandya, S., Milk storage system for remote areas using solar thermal energy and adsorption cooling, *Materials Today*, Volume 28, Part 3, 2020, Elsevier, Pages 1764-1770, ISSN 2214-7853, <https://doi.org/10.1016/j.matpr.2020.05.170>.
- [44] D.S. Hooda and D.K. Sharma, "Non-additive Generalized Measures of 'Useful' Inaccuracy" *Journal of Rajasthan Academy of Physical Sciences*, Vol. 7(3), pp.359-368, 2008.
- [45] H. Ghayvat, Pandya, S., and A. Patel, "Deep Learning Model for Acoustics Signal Based Preventive Healthcare Monitoring and Activity of Daily Living," 2nd *International Conference on Data, Engineering and Applications (IDEA)*, Bhopal, India, 2020, pp. 1-7, doi: 10.1109/IDEA49133.2020.9170666
- [46] D.S. Hooda and D.K. Sharma, Generalized R-Norm information Measures-*Journal of Appl. Math, Statistics & informatics (JAMSI)*, Vol. 4 No.2, 153-168, 2008.
- [47] Pandya, S., Shah, J., Joshi, N., Ghayvat, H., Mukhopadhyay, S.C. and Yap, M.H., 2016, November. A novel hybrid based recommendation system based on clustering and association mining. In *Sensing Technology (ICST)*, 2016 10th *International Conference on* (pp. 1-6). IEEE.
- [48] Dilip Kumar Sharma, "Some Generalized Information Measures: Their characterization and Applications", Lambert Academic Publishing, Germany, 2010. ISBN: 978-3838386041.
- [49] Pandya, S., W. Patel, H. Ghayvat, "NXTGeUH: Ubiquitous Healthcare System for Vital Signs Monitoring & Falls Detection", *IEEE International Conference, Symbiosis International University*, December 2018.
- [50] Ghayvat, H., Pandya, S., "Wellness Sensor Network for modeling Activity of Daily Livings Proposal and Off-Line Preliminary Analysis" *IEEE International Conference*, Galgotias University, New Delhi, December 2018.
- [51] D Datta, S Mishra, SS Rajest, (2020) "Quantification of tolerance limits of engineering system using uncertainty modeling for sustainable energy" *International Journal of Intelligent Networks*, Vol.1, 2020, pp.1-8, <https://doi.org/10.1016/j.ijin.2020.05.006>
- [52] Leo Willyanto Santoso, Bhopendra Singh, S. Suman Rajest, R. Regin, Karrar Hameed Kadhim (2021), "A Genetic Programming Approach to Binary Classification Problem" *EAI Endorsed Transactions on Energy*, Vol.8, no. 31, pp. 1-8. DOI: 10.4108/eai.13-7-2018.165523
- [53] Pandya, S., Ghayvat, H., Shah, J., Joshi, N., A Novel Hybrid based Recommendation System based on Clustering and Association Mining, 10th *IEEE International Conference on Sensing technology and Machine Intelligence (ICST-2016)*, Nanjing, China, November 2016.
- [54] Rao, A.N., Vijayapriya, P., Kowsalya, M., & Rajest, S. S. (2020). Computer Tools for Energy Systems. In *International Conference on Communication, Computing and Electronics Systems* (pp. 475-484). Springer, Singapore.
- [55] Gupta J., Singla M.K., Nijhawan P., Ganguli S., Rajest S.S. (2020) An IoT-Based Controller Realization for PV System Monitoring and Control. In: Haldorai A., Ramu A., Khan S. (eds) *Business Intelligence for Enterprise Internet of Things. EAI/Springer Innovations in Communication and Computing*. Springer, Cham
- [56] Sharma M., Singla M.K., Nijhawan P., Ganguli S., Rajest S.S. (2020) An Application of IoT to Develop Concept of Smart Remote Monitoring System. In: Haldorai A., Ramu A., Khan S. (eds) *Business*

Intelligence for Enterprise Internet of Things. *EAI/Springer Innovations in Communication and Computing*. Springer, Cham

- [57] Ganguli S., Kaur G., Sarkar P., Rajest S.S. (2020) An Algorithmic Approach to System Identification in the Delta Domain Using FAdFPA Algorithm. In: Haldorai A., Ramu A., Khan S. (eds) Business Intelligence for Enterprise Internet of Things. *EAI/Springer Innovations in Communication and Computing*. Springer, Cham
- [58] Singla M.K., Gupta J., Nijhawan P., Ganguli S., Rajest S.S. (2020) Development of an Efficient, Cheap, and Flexible IoT-Based Wind Turbine Emulator. In: Haldorai A., Ramu A., Khan S. (eds) Business Intelligence for Enterprise Internet of Things. *EAI/Springer Innovations in Communication and Computing*. Springer, Cham
- [59] Rajasekaran R., Rasool F., Srivastava S., Masih J., Rajest S.S. (2020) Heat Maps for Human Group Activity in Academic Blocks. In: Haldorai A., Ramu A., Khan S. (eds) Business Intelligence for Enterprise Internet of Things. *EAI/Springer Innovations in Communication and Computing*. Springer, Cham
- [60] Bhopendra Singh, S. Suman Rajest, K. Praghash, Uppalapati Srilakshmi and R. Regin (2020) Nuclear structure of some even and odd nuclei using shell model calculations. Proceedings of the 2020 2nd International Conference on Sustainable Manufacturing, Materials and Technologies. *AIP Conference Proceedings*, 2020, <https://aip.scitation.org/doi/abs/10.1063/5.0030932>
- [61] S. Suman Rajest, D.K. Sharma, R. Regin and Bhopendra Singh, "Extracting Related Images from E-commerce Utilizing Supervised Learning", *Innovations in Information and Communication Technology Series*, pp. 033-045, 28 February, 2021.
- [62] Souvik Ganguli, Abhimanyu Kumar, Gagandeep Kaur, Prasanta Sarkar and S. Suman Rajest, "A global optimization technique for modeling and control of permanent magnet synchronous motor drive", *Innovations in Information and Communication Technology Series*, pp. 074-081, 28 February, 2021.
- [63] Jappreet Kaur, Tejpal Singh Kochhar, Souvik Ganguli and S. Suman Rajest, "Evolution of Management System Certification: An overview", *Innovations in Information and Communication Technology Series*, pp. 082-092, 28 February, 2021.
- [64] R. Regin, S. Suman Rajest and Bhopendra Singh, "Spatial Data Mining Methods Databases and Statistics Point of Views", *Innovations in Information and Communication Technology Series*, pp. 103-109, 28 February, 2021.
- [65] K. Sharma, B. Singh, E. Herman, R. Regine, S. S. Rajest and V. P. Mishra, "Maximum Information Measure Policies in Reinforcement Learning with Deep Energy-Based Model," 2021 *International Conference on Computational Intelligence and Knowledge Economy (ICCIKE)*, 2021, pp. 19-24, doi: 10.1109/ICCIKE51210.2021.9410756.
- [66] F. Arslan, B. Singh, D.K. Sharma, R. Regin, R. Steffi and S. Suman Rajest, "Optimization Technique Approach to Resolve Food Sustainability Problems," 2021 *International Conference on Computational Intelligence and Knowledge Economy (ICCIKE)*, 2021, 25-30, doi: 10.1109/ICCIKE51210.2021.9410735.
- [67] G. A. Ogunmola, B. Singh, D. K. Sharma, R. Regin, S. S. Rajest and N. Singh, "Involvement of Distance Measure in Assessing and Resolving Efficiency Environmental Obstacles," 2021 *International Conference on Computational Intelligence and Knowledge Economy (ICCIKE)*, 2021, pp. 13-18, doi: 10.1109/ICCIKE51210.2021.9410765.
- [68] Pandya, S., W. Patel, An Adaptive Approach towards designing a Smart Health-care Real-Time Monitoring System based on IoT and Data Mining, 3rd *IEEE International Conference on Sensing technology and Machine Intelligence (ICST- 2016)*, Dubai, November 2016.
- [69] Pandya, S., Ghayvat, H., Kotecha, K., Wandra, K., Advanced AODV Approach for Efficient Detection and Mitigation Of WORMHOLE Attack IN MANET, 10th *IEEE International Conference on Sensing technology and Machine Intelligence (ICST-2016)*, Nanjing, China, November 2016.

- [70] Pandya, S., H. Dandvate —New Approach for frequent item set generation based on Mirabit Hashing Algorithm, *IEEE International Conference on Inventive Computation technologies (ICICT)*, 26 August, India, 2016.
- [71] Pandya, S., Patel, W., Mistry, V., i-MsRTRM: Developing an IoT based intelligent Medicare System for Real-time Remote Health Monitoring, 8th *IEEE International Conference on Computational Intelligence and Communications Networks (CICN-2016)*, Tehari, India, 23-25th December 2016.
- [72] Md. Salamun Rashidin, Sara Javed, Bin Liu, Wang Jian, Suman Rajest S, “Insights: Rivals Collaboration on Belt and Road Initiatives and Indian Recourses” in *Journal of Advanced Research in Dynamical and Control Systems*, Volume: 11, Special Issue 04, 2019, Page No.: 1509-1522.
- [73] Laxmi Lydia, E., Kannan, S., Suman Rajest, S. and Satyanarayana, S. (2020) ‘Correlative study and analysis for hidden patterns in text analytics unstructured data using supervised and unsupervised learning techniques’, *Int. J. Cloud Computing*, Vol. 9, Nos. 2/3, pp.150–162.
- [74] Pandya, S., Shah, J., Joshi, N., Ghayvat, H., Mukhopadhyay, S.C. and Yap, M.H., 2016, November. A novel hybrid based recommendation system based on clustering and association mining. In *Sensing Technology (ICST)*, 2016 10th International Conference on (pp. 1-6). IEEE.
- [75] Pandya, S., Vyas, D. and Bhatt, D., A Survey on Various Machine Learning Techniques, *International Conference on Emerging trends in Scientific Research (ICETSR-2015)*, ISBN no: 978-81-92346-0-5, 2015.
- [76] Ravi Kumar Gupta, “Minimum Wage and Minimum Work Hour in India”, *Journal of Advanced Research in Dynamical & Control System*, Vol. 11, 02-Special Issue, pp. 2402-2405, 2019.
- [77] Sooraj Kumar Maurya, Professor Vipin Jain, Roy Setiawan, Alliyarov Ashraf, Kartikey Koti, K.Niranjan, Nik Alif Amri Nik Hashim, and S. Suman Rajest, “The Conditional Analysis of Principals Bullying Teachers Reasons in The Surroundings of The City”, *Productivity Management*, Vol.2 5, No.5, 1195-1214, 2020.
- [78] Roy Setiawan, Keshav Nath, Luigi Pio Leonardo Cavaliere, Klinge Orlando Villalba-Condori, Dennis Arias-Chavez, Kartikey Koti, Girish Bagale, and S. Suman Rajest, “The Impact of Teaching Innovative Strategy on Academic Performance in High Schools” *Productivity Management*, Vol. 25, No. 5, 1296-1312, 2020.
- [79] K.K.D. Ramesh, G. Kiran Kumar, K. Swapna, Debabrata Datta, and S. Suman Rajest, “A Review of Medical Image Segmentation Algorithms”, *EAI Endorsed Transactions on Pervasive Health and Technology*, 2021, doi: 10.4108/eai.12-4-2021.169184
- [80] R. Regin, S. Suman Rajest and Bhopendra Singh, “Fault Detection in Wireless Sensor Network Based on Deep Learning Algorithms”, *EAI Endorsed Transactions on Scalable Information Systems*, 2021, <https://eudl.eu/doi/10.4108/eai.3-5-2021.169578>
- [81] Pandya, S., Wandra, K., Shah, J., A Hybrid Based Recommendation System to overcome the problem of sparsity, *International Conference on emerging trends in scientific research*, December, 2015.
- [82] Mehta, P., Pandya, S., A review on sentiment analysis methodologies, practices and applications, *International Journal of Scientific and Technology Research*, 2020, 9(2), pp. 601–609.