

Solar Powered Dexterous Robot Controlled by Mobile Phone

*¹M.Sivachitra, ²V.Priya, ³Remy lumin benedict, ⁴S.Suganeshwaran, ⁵H.Anish

¹Department of Electrical and Electronics Engineering,

Professor, Kongu Engineering College, Erode, Tamilnadu, India.

^{2,3,4,5}Department of Electrical and Electronics Engineering, Kongu Engineering College,
Erode, Tamilnadu, India.

¹ siva.chitra3@gmail.com, ² vpriya1000@gmail.com, ³ theremylumin@gmail.com

Abstract

This paper expounds the novel approach to a multi-functional robot which includes the technology that supports Bluetooth communication for monitoring the physical parameters in uttermost environment conditions and acts as a substitute for human surveillance. This paves path for smart monitoring and provides better solution for loss of lives under harsh terrains. The bot contains multiple sensors integrated to a microcontroller which predominantly controls both the motion of the robot and multitude data from the sensors and imparting it to the user end. This also utilize solar energy for power reliability and it also uses battery for power backup. It also comprises of a camera module for probe the real time instances. A completely unique approach of Geo-tagging is used in the proposed work, which shows the ultimate path from start to the stop point. This has the sole purpose of computing the entire route of the robot within the graphical form in case if the robot lost its track. The key feature of this robot has two operating modes: Automatic and Manual mode. In case of sceptical situations, the user may take over the control in order to proceed further operations.

1. Introduction

Robots are used to effectively reduce the work power and escalate the performance and to minimise the errors from the outsets. It acts as a perfect replacement for human lives. The Robot is mainly conceived in order to make the dimensions small so that it can be able to probe through the tunnels, mines. Miniature of size is achieved by reducing its body ratio. The Design of the robot is more condensed so that the weight of the robot gets minimised. It is a minimalistic approach to frame such low-cost robot for monitoring purpose. The robotic technology has vast influence over various applications such as automation in Railways, Roadways, Healthcare, Defence, Surveillance[1-4],[10] etc., There are many situations where human cannot monitor or inspect the conditions in mines and tunnels. Tunnels are highly useful not only for water management but also in case of Communication purposes. Labour force cannot examine underground mines and tunnels for immediate inspection in case of unusual fault detection. As it operates in two modes, Automatic mode and manual mode, this enables the user to manoeuvre the bot both on field and remote conditions. Initially bots are programmed to carry through specified tasks. Lately with the evolution of microcontrollers, the robot can be controlled by many technologies such as IoT, DTMF, Bluetooth, Wifi, Raspberry Pi, FM signal etc., The wireless technologies has an high edge over when it comes to transmission speeds, it holds minimal space, low capital, installation is handy. These technologies has both their pros and cons. This paper mainly focus on enhancement of operating range, Low cost efficient and also minimalistic design approach. The Robot is capable of acquiring high precision monitored data than that of human proctoring. It acts as a life saver at times of natural calamities. It uses Solar power for power reliability where the future scope is propitious. This also uses a battery for power backup in case of long run times. The advent of mobile phones has a drastic influence on the monitoring and receiving data

from run time. These mobile phones can be easily integrated with the microcontrollers used in the robots and it can efficiently guide the robot in the manual mode and monitor the parameters. These can be a better solution in order to record data and able to review the data for further analysis. The data can be immediately received via the Bluetooth module. The vital variables like temperature, humid level, obstacle detection, location tracking, Geo-tagging, live video can also be accessed through mobile phone. This multipurpose bots will be well equipped with multiple sensors and can be used in monitoring instead of human intervention. The robots which were used during last decades has low operating range and high power consumption. It has drawbacks that affects the performance of the robot. So the revolution flourished and the automation and robotic technology bloomed. The advent of nano sensors and ICs made this possible and the ICs used consumed meagre amount of power, and this is the breakthrough in energy management of robots. The mechanical design comprises of aluminium steel frame which is compact and it uses solar panel too. The solar panel is the source of energy where it can be charged before operation and it can be recharged after the completion of task. On board batteries store the charge and helps the bot to run when it requires long run. This robot is cost efficient and provides best solution for human monitoring under mines.

2. Related Work

[5] Here the robot has FM system where the antennas are kept close for better communication. It requires wider frequency channel in FM transmission. FM station is needed to send the signal for long distance.

[6] This robot has more theoretical sense than practical aspects and it lacks obstacle avoidance system but has good interface between robot and controlling device which in this case is a mobile phone.

[7] This robot has great design specifications. Even though this robot runs on its own, it cannot charge automatically and needs to be charged manually.

[8] Robot has a simplified mechanical design with minimal operations. Here the data was not able to fetch during the run time of the robot from the user end. It is less applicable when it comes to mine and tunnel area surveillance.

[9][11][12][13] Here the robot uses DTMF technology, which is an out-dated technology. The main drawback is, It works only in keypad phones and it is not reliable. This technology is very old compared to the newer technologies available in the market which has high speed transmission and reception.

3. Proposed Work

Initially Robots used batteries as power source. Thus, it becomes inconvenient to use at the end of day. Even though it's rechargeable and used just for a shorter duration and these surveillance robot sense one or two physical quantities. It has shorter operation range and there is no automatic control in case of manual operation failure. In earlier days robots used former technologies and are expensive to develop. Existing robots use expensive video camera for live video streaming for manual control. The Robot developed by us has five main modules. They are Power supply module, Driving module, Communication module, Sensor module, Obstacle avoidance module. In tunnel area, much surveillance is required to prevent accidents. To unravel this problem, developed robot can enter tunnel and monitor. The robot system is provided with

sensors that can alert user when some anomaly appears within the range while robot is functioning. The main feature of this robot is its execution of different tasks in night and rough areas. This robot has two modes. Mode one is automatic mode and the other is user controllable mode. The robot is controlled by ultrasonic sensor in automatic mode. Whenever the situation arises, the robot will start moving to the location and thereafter it will scan for clues. It will send the location through internet and text the prior saved message to the operating switching device if the result is positive. By detecting the readings of sensors, it can easily determine the temperature, light and gas present within the given area. Therefore, critical conditions can be avoided and preventive measures are successfully implemented in the proposed system.

3.1. Problems identified in the existing method

- a. Most of the robots used charged batteries as source of power. Thus it becomes inconvenient to use it for long run.
- b. Earlier surveillance robots sense only one or two physical quantities.
- c. Prevailing robots use high cost video camera for streaming live scenarios for manual control.

3.2. Objectives

- a. This robot is typically miniature in size. so, they're enough capable to enter in tunnels, mines and little holes in building and in addition have capability to survive in harsh and difficult climate.
- b. The user can control the movement of robot by using bluetooth communication.
- c. Powered by solar energy and has manual and automatic mode
- d. Various parameters are measured for controlling the robot.

4. Hardware Implementation

a. Battery

The Bot uses DC supply as power source. For DC power supply, bot consists of two batteries mounted to the frame where both the batteries are 6v connected in series and current rating is 1.35 Ah, connecting in series produce 12V. This battery is chargeable via solar panel and charging circuit connected to it.

b. DC Motor

The Bot uses two motor for manoeuvre, here the dc motor used is 12V, each draws current of 0.1A, each motor rotates at the rpm of 10-50 rpm and produces torque of 1.5Kg.cm. Their individual weights are 130g and it can run in environment up to 40⁰ C.

c. Servo Motor

This dexterous robot uses a servo motor for special purpose. The servomechanism serves to mount the camera, ultrasonic and PIR sensor. This servo motor is mounted in the front portion. By using this servo motor action, the user can change the direction of the servo motor to left, right and straight to know the environmental conditions without changing the whole body of the bot. The motor along with the sensors turns and fetch the environmental conditions. The servo motor operates at a voltage of 4.8-8.0V, where the speed is 0.12sec/60degrees (4.8V) 0.10sec/60degrees (6.0V), and its weight is 8.5g.

d. Ultrasonic Sensor(Specification)

The ultrasonic sensor is mounted on the servo motor to avoid the obstacle, and it operates at 5v DC supply, draws current of 30mA, can cover a range of about 2cm to 3m. This ultrasonic sensor is small in size where its size is – 22 mm H x 46 mm W x 16 mm D

(0.84 in x 1.8 in x 0.6 in).

e. Solar panel

Solar panel increases the power reliability, it helps to charge the two 6V batteries of the bot. The solar panel is mounted on the batter above the bot in such a manner to absorb solar power, its maximum voltage is 21.02v at open circuit and short at 0.3 amps.

f. ESP Camera

ESP camera helps to stream video and photo to the user, and its is mounted to the servo motor, where the servo motor rotates and helps to see further in various directions, it helps the user to play with various parameters like color correction, brightness, contrast etc., It has -Low power 32-bit CPU, and can also serve the application processor.ip address is 192.168.43.200.

g. PIR Sensor

Passive Infrared sensor is used to detect human motion and it is mounted on the servo motor. Its operating voltage is 3 to 6v DC, where it draws power of about 130 μ A under idle condition, 3 mA active condition (no load). Its operating temperature range is 32 to 122 °F (0 to 50 °C).It can detect a person up to approximately 30 ft away in reduced sensitivity mode.

h. Gas Sensor

Gas sensor is mounted on the frame of the bot, and it gets power via the battery through the 7805 regulator where its voltage rating is 5V. It can operate in the temperature ranging from -20⁰ C to 50⁰ C.

i. Thermistor

Thermistor-103 is used for measuring the temperature. It shows the temperature in a graphical form in mobile phone at user end. The Thermistor operating range is -20⁰~+125⁰C, and it draws a maximum power of 500mW.

j. Metal Detector

Metal detector is placed below the wooden chassis of the bot and it is placed in such way to detect the metal at the surface level, and its operates is at the voltage of 5v.

k. Bluetooth

HC-05 is used in this bot to connect with user via Bluetooth it is low power operating device which requires 1.8V to 3.6V, it has in build antenna that connect with the user.<https://play.google.com/store/apps/details?id=com.keuwl.arduinoblueetooth>

l. Geo Tag

GEO TAG is a small chip which pairs with the user device in order to show the mapping of the bot in case of under ground or tunnel operation. This geo tag continuously transfers the location of the bot in real time. This is a novel idea where it will be useful in case of retrieval of the robot if lost. It has given an additional cell power so that it can perform independently, even if the system power shuts down, geo tag can able to transfer the location to the user. Geo tag : <https://play.google.com/store/apps/details?id=com.lenzetech.isearchingtwo>

m. ATMEGA 328p

ATMEGA 328p is the brain of this bot which helps to control the total operation

of the bot and it operates between 1.8-5.5 volts. The device achieves output approaching one MIPS per megacycle. It is a 28 pin IC capable of doing various tasks.

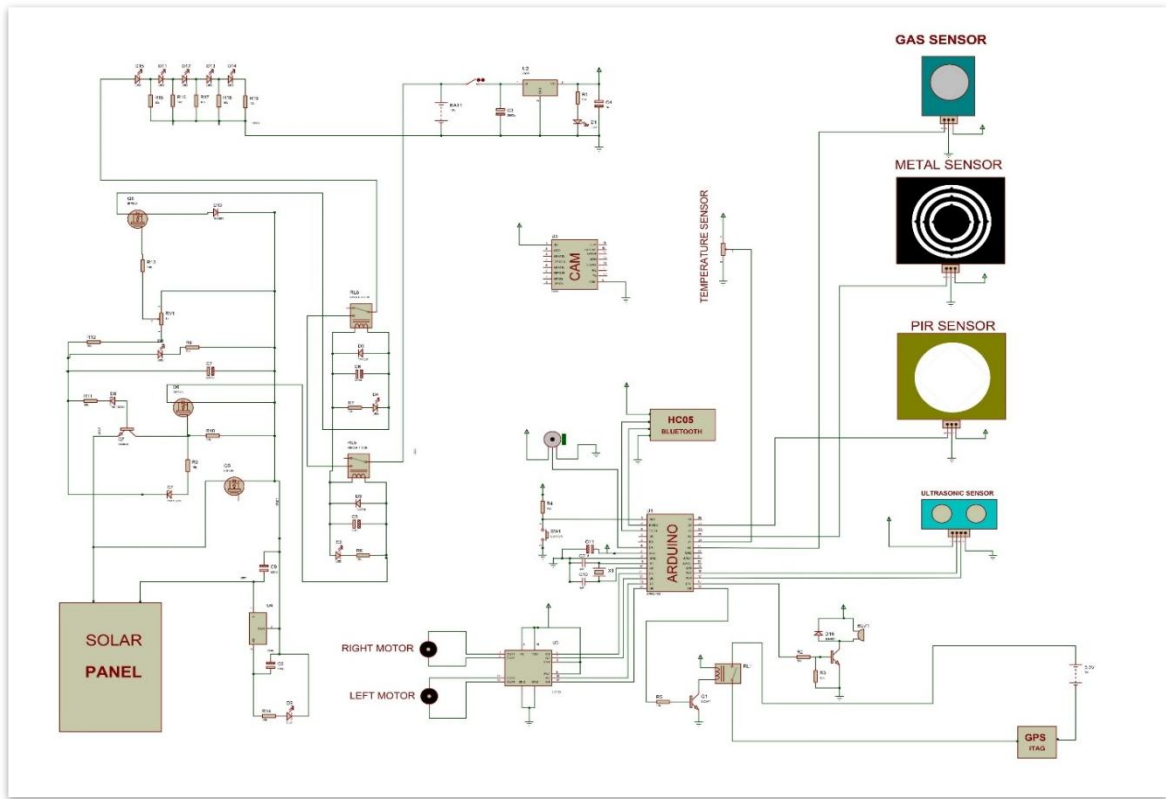

Figure 1: Circuit Diagram of the Robot.

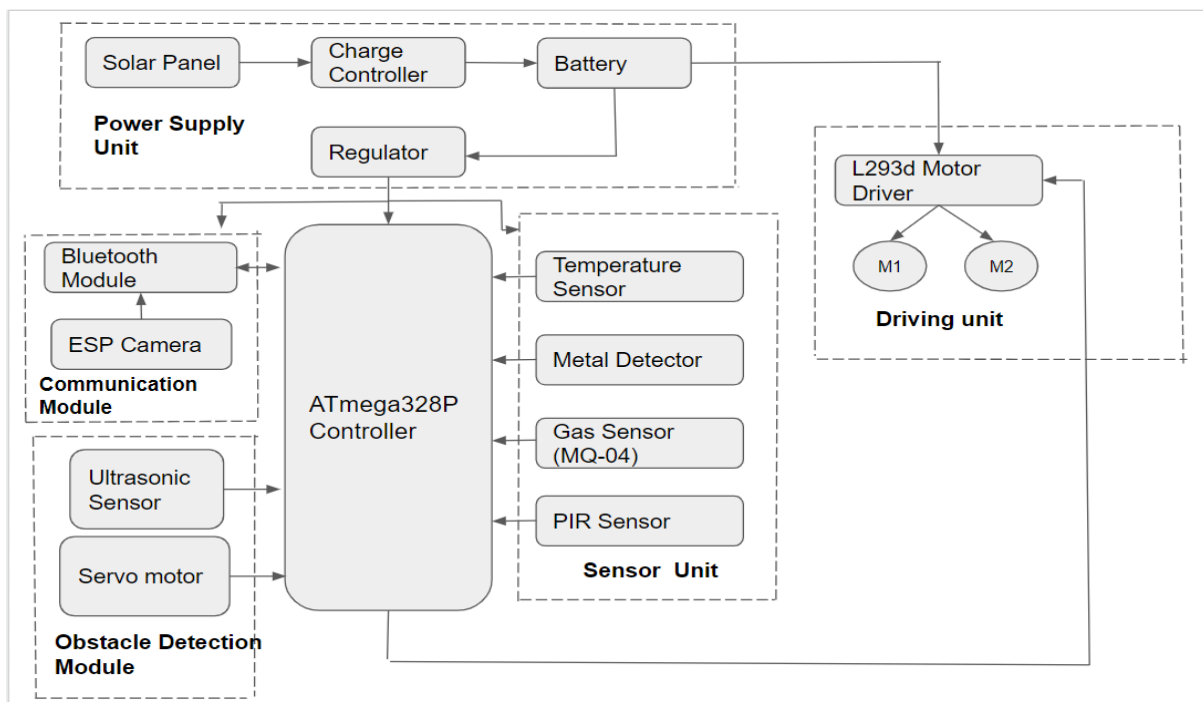

Figure 2: Block Diagram of the Robot.

The block diagram consists of 5 units. Namely, power supply unit, communication module, obstacle detection module, sensor unit and driving unit. All these units are controlled by ATmega 328p controller. Power supply unit provides power to all units and the controller. It also charges the battery using solar panel. Obstacle detection module and driving unit works hand in hand to drive the robot. Driving module uses motor driver to run wheels and both ultrasonic sensor and servo motor are used for obstacle detection. Sensor unit has temperature sensor, metal detector, gas sensor and PIR sensor. All sensor senses their respective parameter and sends it to user via communication module. Which has Bluetooth module and camera for real-time data transfer and live stream the robot's path. Geo tag is used for locating the robot anywhere in the robot.

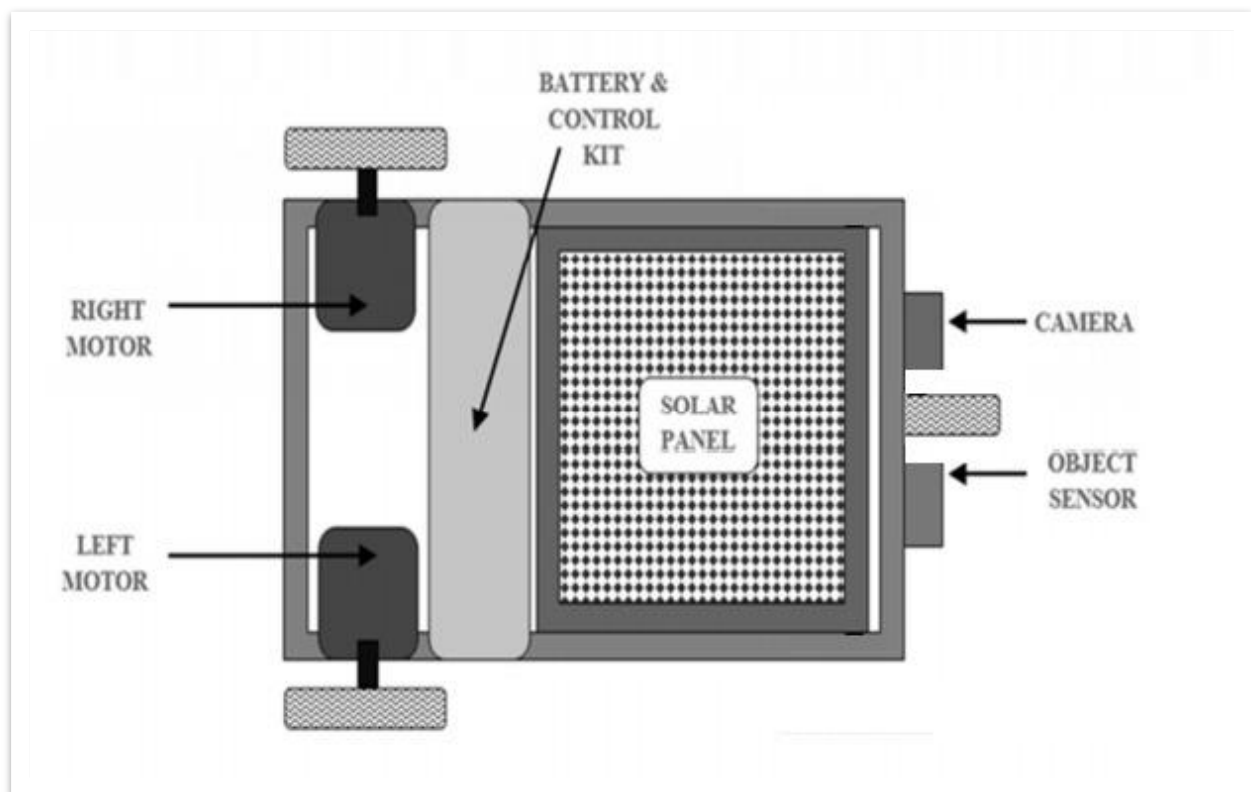

Figure 3: Mechanical Structure of the Robot.

5. Results

The Proposed Solar Powered Dexterous Robot has been implemented practically to observe the performance of the system. During the operation it is observed as proposed the bot runs in both manual and automatic mode, we can control the bot by using the mobile phone through buttons provided. Whenever the user fails to command, the bot automatically switches to the automatic mode. User gets real time position via the indicators in the mobile phone as mentioned in screenshot as **R** for right, **L** for left, **F** for front, **RE** for reverse, **SP** for stop. The user can get the real time video streaming and stills of the environment in the mobile phone itself. This camera is comparatively cheaper and allows the user to play with various parameters like brightness, switching the video quality, contrast of the video, horizontal and vertical flip options, and much more.

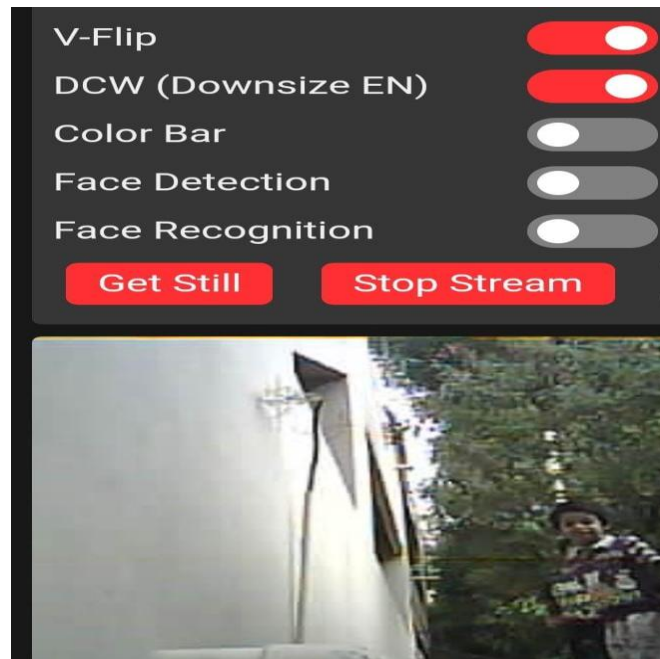

Figure1:Image Captured from the bot's Camera in user mobile.

The ultrasonic sensor does its job in obstacle avoidance without any trouble. The PIR sensor works on the principle where it notifies the user if there is any object intervene in tunnel especially the persons nearby and update to the user through indicator in the mobile phone as denoted as **P** in the screenshot given below. The ultrasonic sensor, the PIR sensor and the camera is mounted above the servo motor and this servo motor brings novelty to the bot, servo motor turns to left, right and centre position along with mounted camera, PIR and ultrasonic sensor without altering the Bot's body, so the user get a greater clarity about the environment.

Metal detector mounted below the frame helped to find out the metal object in the surface and wherever it finds a metal it shows the user through indicator **M** as shown in the screenshot. The temperature of the environment is sensed by the Thermistor and the temperature is indicated to the user in as **T** mentioned in screenshot, gas level is sensed using the gas sensor and its level is indicated to the user as **G** mentioned in screenshot.

This bot can able to update its Path travelled in a graph format thus the user can get clear information about its path and this path can used for further reference, this path is shown in **Route** graph in screenshot, this graph pushed our novelty from other bots to a greater height.

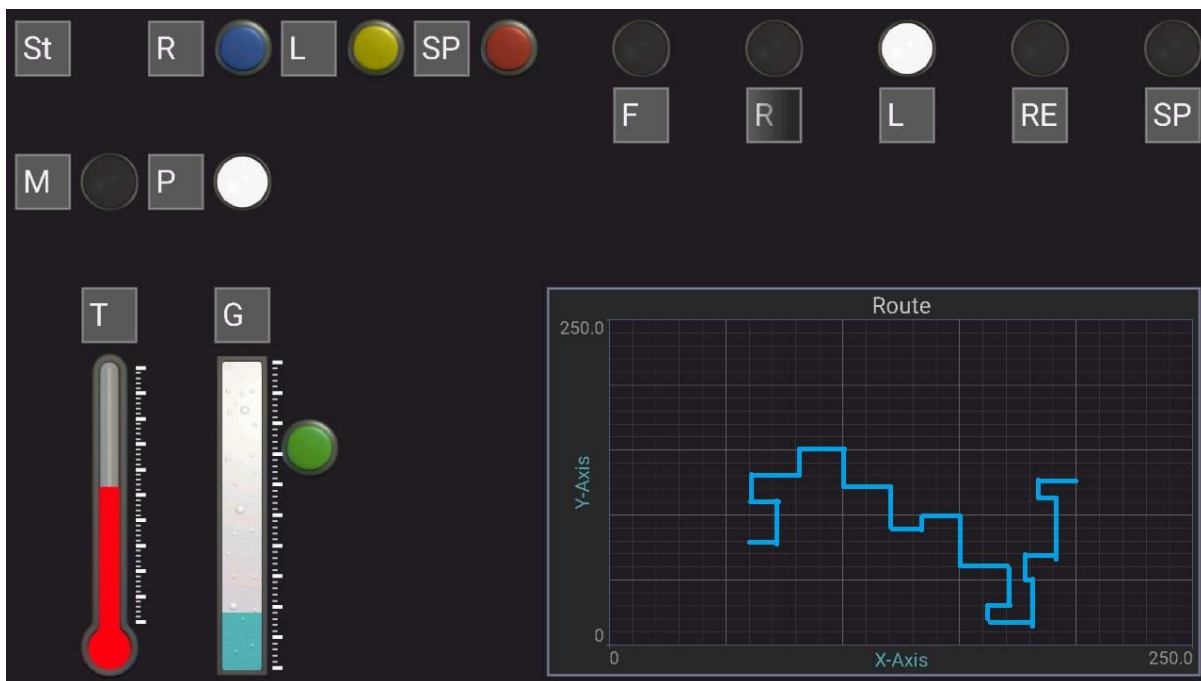

Figure2: Screenshot of the Bot's activity captured in mobile phone

From observation this bot sends the location of geo tag to the user's mobile phone, the geo tag is powered via a separate cell power and it has an advantage that it can able to send its location even the whole Bot shuts down, so the user can able to know the location of the bot even in extreme power failures.



Figure3: Screenshot of the location of the bot.

Solar power helped to bring more power reliability to the bot as proposed, The bot is tested in multiple terrains and tunnels the results came out fine as proposed without any trouble.

6. Conclusion

This robotic vehicle with different sub modules can widely be used as surveillance robot for security purpose and emergency rescue operations where human cannot footpace. This is an autonomous movement bot with obstacle avoidance, and may run in battery also. It operates in automatic and user controlled mode. The system is developed for various applications as a spy robot, for remote surveillances, bomb detection and fire detection. It plays an important role in practical applications where human has restraints to work.

Reference

1. M.S.Minu, Medharametla Alekya, Manduva Supriya, Polamreddy Malvika: 'Arduino Controlled Multipurpose War Field Spy Robot for Military Surveillance', International Journal of Advanced Science and Technology, Vol. 29, No. 03, (2020), pp. 5485 – 5494.
2. Md. Mamunoor Islam, Mehdi Hasan Chowdhury: 'Design and Fabrication of an Unmanned Video Transmitting Tele-bot using 3G GSM Network', International Conference on Computer, Communication, Chemical, Materials and Electronic Engineering, IC⁴ME²-2016, 23~24 March, 2016, pp. 59 – 62.
3. Sandeep Bhat, M Meenakshi: 'FM based wireless video transmission for an autonomous robot path control in military applications', International Journal of Conceptions on Computing and Information Technology, Vol. 4, Issue 5, July' 2016, pp. 11 – 13.
4. Sharanabasappa Sali, Shabinabanu, Neelambika, Supriya K, Shreekant H: 'Robot Control using Android Mobile with Solar Panel', International Journal of Science Technology & Engineering, Volume 2, Issue 11, May 2016, pp. 239 – 244.
5. S. A Joshi, Aparna Tondarkar, Krishna Solanke, Rohit Jagtap: 'Surveillance Robot for Military Application', International Journal Of Engineering And Computer Science, Volume 7, Issue 5, May 2018, Page No. 23939-23944.
6. Vidya Kodgirwar, Shreeya Deshpande, Reema Damle, Tejal Kadam: '7th Sense: A Multipurpose Robot For Military', International Research Journal of Engineering and Technology, Volume: 05, Issue: 05, May-2018, pp. 3536 – 3538.
7. Divya Singh, Manish Verma, Ranchana Sahu, Shruti Kantode, Shailendra Singh: 'Android Application Based Robotic Vehicle', International Journal of Scientific Research in Computer Science, Engineering and Information Technology, Volume 2, Issue 3, pp. 583 – 587.
8. Ritika Pahuja, Narender Kumar: 'Android Mobile Phone Controlled Bluetooth Robot Using 8051 Microcontroller', International Journal of Scientific Engineering and Research, Volume 2 Issue 7, July 2014, pp. 14 – 17.
9. Ashish Jadhav, Mahesh Kumbhar, Meenakshi Pawar: 'Cell Phone Controlled Ground Combat Vehicle', International Journal of Computer and Communication Engineering, Vol. 1, No. 2, July 2012, pp. 114 – 116.
10. Khushwant Jain, Vemu Suluchana: 'Design and Development of Smart Robot Car for Border Security', International Journal of Computer Applications, Volume 76, No.7, August 2013, pp. 23 – 29.
11. Punithavathani, D. Shalini, K. Sujatha, and J. Mark Jain. "Surveillance of anomaly and misuse in critical networks to counter insider threats using computational intelligence." Cluster Computing 18.1 (2015): 435-451.
12. Chang, Jinping, Seifedine Nimer Kadry, and Sujatha Krishnamoorthy. "Review and synthesis of Big Data analytics and computing for smart sustainable cities." IET Intelligent Transport Systems (2020).
13. Song, Hesheng, and Carlos Enrique Montenegro-Marin. "Secure prediction and assessment of sports injuries using deep learning based convolutional neural network." Journal of Ambient Intelligence and Humanized Computing 12.3 (2021): 3399-3410.