

Automatically Distilled Water Filling in Inventory Battery by Using Internet of Thing Approach

S. Padmavathy¹, H. Vinoth Kumar², K.K. Sharath Kumar³, R. Vinoth⁴, A. Yokesh⁵

¹Assistant Professor, Mechanical Engineering, M. Kumarasamy College of Engineering, Karur, Tamil Nadu, India.

²Assistant Professor, Mechanical Engineering, M. Kumarasamy College of Engineering, Karur, Tamil Nadu, India.

³UG Student, Mechanical Engineering, M. Kumarasamy College of Engineering, Karur, Tamil Nadu, India.

⁴UG Student, Mechanical Engineering, M. Kumarasamy College of Engineering, Karur, Tamil Nadu, India.

⁵UG Student, Mechanical Engineering, M. Kumarasamy College of Engineering, Karur, Tamil Nadu, India.

ABSTRACT

During battery charging water is renewed into nuclear number 8 and nuclear number 1 through electrolysis, prompting the liquid levels inside the battery little by little bringing down. lacking liquid in batteries is one in every one of the most reasons for untimely imperfections. it's crucial with the goal that each battery cell has spare liquid in order to stop the amazingly harming drying out of the plates. it's directed to envision the liquid levels inside the cells at least every ten energizing cycles and high with water once required. skill has educated U.S. that physically beating up batteries conveys part of hazard with it. the legitimate degree of arrangement is vital. Levels that square measure too low square measure hazardous for the soundness of the plates, and if the sum square measure excessively high, they'll flood all through charging prompting the deficiency of corrosive, in addition as harming the battery and in this manner the machine. A programmed water filling framework eliminates these issues and makes investment funds in support costs. Our framework helps on quicker, simpler and more secure fixing from batteries, conjointly helps in standard upkeep and hence the effect that this has on the life expectancy of the battery.

KEYWORDS

Fluid Level, Water Filling & Battery.

Introduction

There are many necessary steps to properly maintaining a deep cycle battery. we have a tendency to clearly understand they're a monetary investment, thus why not take correct care of them to urge the foremost life as potential. All steps of battery maintenance are vital and none of them ought to be over looked. one in all the best selections to form is exploitation H₂O to fill your batteries. The solution in an exceedingly flooded deep cycle battery may be an answer of acid and water. exploitation distilled or deionized water is advocate as a result of it's free from further minerals you'd notice in water like regular H₂O. Adding chemicals and minerals will considerably decrease the lifetime of batteries. H₂O ought to be the sole belongings you ever fill in your deep cycle batteries. ne'er add further acid or solution answer, this could conjointly diminish the battery life. H₂O will be purchased at any foodstuff and is extremely cheap.

Construction

The base frame to deal with entire parts is invented with the assistance of sq. tubes and channels by metal cutting and metal change of integrity method known as fastening. The reservoir that contains H₂O to be stuffed within the battery is placed on the bottom frame. A DC pump is submerged within the reservoir, whose outlet is connected with the instrumentation of battery through flex hose. The water level indicator is put in within the instrumentation of battery. The DC pump is connected to the output pin of microcontroller and equally water level indicator is connected to the input pin of controller. To access the management of system through web, a LAN module is connected to the controller. On the opposite hand an online page is made to manage the complete system through human interaction.

Literature Review

G. Yuvaraj, V. Anusha Hindu Deity - Monitoring Water Distelle in Battery Misuse the Internet of Things (IOT)

Nowadays, electronic devices play an important role in ensuring a comfortable way of life. In the event of power, people square measure abusing it for 24by7 as if there are of acquiring household apparatuses square measure of electronic gadgets. On these lines if there is any force misfortune in then of running any electronic gadgets it ought to land up in hurt, later on to anticipate they were of abuse the battery to work moment once influence misfortune. As a whole, we understand that their square measure varies types of water-powered batteries. As a result, throughout this paper, we'd like to investigate associate degree approach to the board the batteries voltage abuse IOT (Internet of Things). It was of obtaining a low cost and reducing the time unit and time-productivity and worth the framework used in it was of metre. It had been of misusing the Raspberry Pi for inspecting and modifying the qualities. Despite the fact that they were abusing Arduino, cloud for causing the knowledge

Muhammad Farrukh Irfan Ahmed Halepoto - Bhawani Sitar Player ChowdhryHameedullahKazi - Vogue and Implementation of PLC Basically Based Mostly Automatic Liquid Distillation System

This paper proposes the composing partner degreed execution of a programmed fluid refinement framework. The model is planned for primarily a pair of capacities: fluid refinement and tank level. Strategies/Statistical Analysis: model gave includes a method for analytic the mix (Methanol and water) and improves the get along by handling the entire framework exactly. The model planned offers an easy predominant and waiting for example knowledge securing of liquid level with the assistance of PLC S7200. refinement is that the elemental topic behind this investigation work that assumes an enormous half in an exceedingly few ventures in overseeing effervescent of fluids and fluid levels. Discoveries: At introductory stage the execution of a solid mechanical vogue is created to support immoderate temperature; aside from this a comfort board is framed to physically the executives and show the condition of actuators. Finally, PLC interfacing and programming with electrical elements (level locator circuit, measuring instrument, siphon, radiator, magnet valve so forth) is finished for accomplishing the economical and speedy programmed strategy. within the last vogue was tried various things with real answer, it had been half-tracked down that ninetieth of the liquor was recovered in buildup chamber; collectively temperature linearization was resolved at some point of the strategy. Applications: Error free element and speedy drive makes this model indispensable for a number of ventures that influence large boilers anyplace engineers tackle with prevailing and looking at of fluids for instance sugar plants, milk industrial facilities so on.

Pravin Kalubarme Sir. Sushilkumarmadane Sir. Abhijeetmalve Miss. Reshma Bagal Sir. Shivaji Kambale - Automatic Container Filling System

The venture is designed for programmed bottle filling and count. This venture can precisely check the jugs abuse IR sensors. the framework is freed from human intercessions. The intensity of this procedure is high and it helps in programmed bottle filling and count. framework is that the primary half which has Arduino programming to oversee differed parts during this framework. it's intended to take out the shifted issues looked by little scope enterprises though pressing the containers. this procedure works precisely and decreases working and activity costs severally.

Emmanuel Assare-Mokwah - Style of Automatic Stockpiling Tank Filling System Utilizing A Programmable Logic Controller

The drinkable cleansing exchange has gotten one in every one of the greatest ventures in African country. a look directed on the National Association of sack and prepacked Water Producers (NASPWAP) proposes that there are in regards to six,000 of such enterprises enlisted in African country inside the most recent 5 years. by and by stacks of water cleaning frameworks in African country are either manual or semi-computerized with the past inside the lion's share. inside the shortfall of computerization, plant administrators should truly screen execution estimations of water and instrumentality to work out the best settings on that to run the get together instrumentality. some of the programmed frameworks being used use transfer rationale identified with huge measures of electrical wiring. Manualization of a water purging cycles opens the technique to certain inadequacies or difficulties. in an extremely

water refinement unit like Everpure African country limited, there are with respect to 250 water tanks and 100 worked by hand valves or units to oversee in this way watching is intense and presents a few difficulties. This mechanical venture was intended for concocting a programmed arrangement of capacity tank filling utilizing a programmable rationale regulator. the arranging was affirmed to have the benefit of lessening human contact with the framework and ensuring its strength. the strategy utilized in this task portrays the most parts utilized in the framework style like fluid level sensors, siphon, and magnet valves. The rate (utilizing existing data from Everpure African Nation Limited), operational pressing factor and framework head were determined to pick the right parts for the situation. The stepping stool rationale for the capacity tank filling framework was authorized by reenactment utilizing a Programmable Logic Controller (PLC). Pico delicate six reenactment programming bundle was wont to exhibit the mechanization at tank filling and tank remotion in regard to the valve hole and closing. To legitimize the benefits which will be expanded from computerizing the tank filling framework, value decrease and time reserve funds examination were determined. Less human contact proposes that less cost as far as work, support, service charges squander. The framework gives territory to improvements, subsequently sensors and siphons will be exaggerated furthermore as upgrading the security of the siphon.

Working Principle

Initially the amount of H₂O keep within the reservoir is cross checked, the micro chip is turned on to manage the system through web. once the user logged to its accessing web content, they will monitor the amount of water within the instrumentation. Once the water level get decreases to the allowable limit user will choose the subsequent 2 ways that to fill the water. the primary approach is associate degree automatic approach within which water is mechanically stuffed within the instrumentation through associate degree activation of DC pump. so as to access this manner user on choose the automotive vehicle key in an exceedingly software package. The second approach may be a manual methodology within which user must activate the DC pump by watching the amount of water within the instrumentation. exploitation this 2 ways that the additional advanced methodology of H₂O filling within the battery is performed in a straightforward and effective manner.

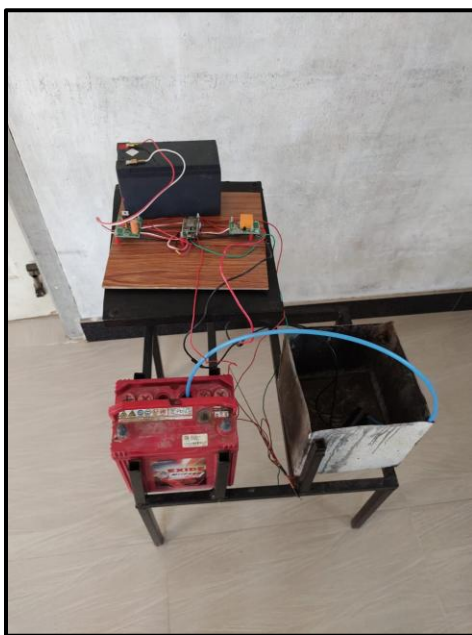

Fig. 1. Project Setup

Internet of Things

The Internet of Things (IoT) denotes the organisation of physical items—"things" or articles—that are outfitted with sensors, programming, and various advancements for the purpose of associating and exchanging data with various

gadgets and frameworks over the internet. Things have advanced on account of the union of diverse advances, amount investigation, AI, exchange merchandise sensors, and inserted frameworks. previous fields of put in frameworks, remote symbol organizations, the board frameworks, robotization (counting home and building mechanization), et al all increase facultative the snare of things. within the client market, IoT innovation is usually substitutable with stock addressing the likelihood of the "shrewd home", even as gadgets and apparatuses (like lights, indoor regulators, home security frameworks and cameras, and various home machines) that support one or more basic biological systems and can be controlled by devices known as plot, such as low-cost phones and keen speakers. IoT likewise will be used in treatment frameworks. there's assortment of unbelievable contemplations with regard to risks within the event of IoT, particularly within the areas of protection and security, and so exchange and body moves to manage these contemplations have started even as the occasion of worldwide norms.

Introduction

The Internet of Things may also be an intriguing issue in the market, but it is far from a perfect plan. In the mid-2000s, Kevin Sir town Ashton was laying the groundwork for what would become the Internet of Things (IoT) at MIT's AutoID operating environment. Sir Town Ashton was one of the forefathers. World Health Organization had this idea while testing for manners by Proctor and Gamble could improve its business by connecting RFID data to the internet. In any case, the musing was simple. If all things in life had identifiers and remote property, These articles will communicate with one another and will be monitored by PCs. Sir Town Ashton stated in a 1999 article for the RFID Journal: "In the event that we have a tendency to tend to had PCs that knew it all there was to grasp with regard to things—utilizing information they assembled with none work with from u. s. of America - we'd have the choice to trace and tally everything, and terribly deflate waste, misfortune and value. we'd see once things needed substitution, fixing or reviewing, and whether or not they were modern or past their best. we'd like to have interaction PCs with their own proposes that of get-together information, in order that they can see, hear and smell the world for themselves, within and out its arbitrary greatness. RFID and symbol innovation alter PCs to require a goose at, established and see the world—without the restrictions of human-entered information."

At that time, this vision needed important innovation upgrades. All things thought of, anyway would we have a tendency to tend to interface everything within the world? What variety of remote interchanges will be designed into gadgets? What changes would want to be created to this internet foundation to assist billions of in progress gadgets imparting? What may management these gadgets? What have to be compelled to be created to form the arrangements value powerful? there are further queries than answers to the IoT thoughts in 1999. Today, a number of these deterrents square measure settled. the measurements and value of remote radios has planned colossally. IPv6 licenses u. s. of America to relegate a correspondences address to billions of gadgets. material science firms square measure incorporating Wi-Fi and cell remote property into a good dissent of gadgets. ABI examination gauges over five billion remote chips will send 2013. transportable information inclusion has improved extensively with a number of organizations giving broadband paces. whereas not extraordinary, Battery technology has advanced, and star re-energizing has been integrated into a variety of devices. With the passage of time, there will be billions of articles associated with the organisation. For example, Cisco's Internet of Things cluster (IOTG) predicts that there will be over fifty billion connected devices by 2020. IoT denotes a framework in which things in the specific world, and sensors among or related to those things, square measure linked to the internet the online the net via remote and wired web associations. These sensors can use a variety of local area associations, including RFID, NFC, Wi-Fi, Bluetooth, and Zigbee. Sensors will also have wide-area capabilities such as GSM, GPRS, 3G, and LTE.

Connect Every Lifeless and Living Things

The early stages and organisation of web of Things networks began with the association of trendy instrumentation. Today, the vision of IoT has expanded to include everything from mechanical instruments to everyday items. From gas turbines to vehicles to utility metres, the types of things change. It would accept living organic entities such as plants, cattle, and humans. For example, the Cow Pursuit Project in Essex uses information gathered from radio positioning labels to monitor cows for medical condition and track group behaviour. Wearable problem-solving devices and processed wealth gadgets, Nike+ Fuel Band and Fitbit are examples of how people are interacting within the Internet of Things scene. Cisco has expanded the meaning of IoT to Infobahn of Everything (IoE), which connects people, places, articles, and things. Basically, you will be able to be a part of a contraption and property to

take an interest in the new associated environments.

Use Sensors for Information Grouping

The items with which they are associated will have one or more sensors. Every contraption will monitor a specific condition such as space, vibration, movement, and temperature. In the Internet of Things, these sensors will accompany one another and to frameworks that can see or bless information from the sensor's information takes care of. These sensors can give new information to AN organization's frameworks and to folks.

Modification What Assortments of Issue Impart Over Associate in Nursing Scientific Discipline Network

Previously, people conversed with both other people and machines. Consider what would happen if your entire instrumentation could speak. What would it not advise you on? IoT-enabled things will share information about their current state as well as the surrounding environment with people, programming bundle frameworks, and optional machines. This information is consumed in quantity or gathered and shared at predetermined intervals. Moving forward, everything will have a processed character and property, implying that you can decide, follow, and converse with objects. IoT data differs from traditional processes. The data is small and continuous in transmission. The quantity of devices, or hubs, that are associated with the organisation square measure higher in IoT than in traditional computer process. Machine-to-Machine correspondences and data drawn from the gadgets, as well as the organisation, will enable organisations to change positive essential tasks whereas not reckoning on focal or cloud chiefly primarily based applications and administrations. These credits blessing freedoms to assemble a huge modification {of information {of data of data of knowledge} on information} anyway put together supply difficulties concerning composing the affordable information systems administration and security.

Use of Business

Every business is affected by IoT. Furthermore, it is versatile. The Internet of Things will alter the types of devices that interface with an organization's frameworks. These new connected devices will generate new knowledge collections. The Internet of Things will assist businesses in gaining expertise. Capture data from a wide range of units, improve activities, and increase client satisfaction. IoT can also have a significant impact on people's lives. It will improve peace, transportation, and treatment by collecting more data and exchanging it more quickly. whereas their area unit a number of alternative ways that Infobahn of Things might have an effect on society and business, there are a unit a minimum of three important advantages of IOT that will have an effect on each business, that include: correspondence, the executives and price investment.

Communication

IoT transmits data to people and frameworks such as the state and strength of a battery (for example, whether it is on or off, charged, full, or void) and data from sensors that can detect a person's vital signs. Many times, we have a tendency to did not approach this information previously, or it had been gathered physically and frequently. For example, an IOT-enabled HVAC framework can report whether or not its filter is clean and functioning properly. Almost every organisation includes a classification of resources that it would use. GPS-enabled resources can communicate their gift area and development. Trucks, for example, require a lot of space. In any case, it's put together material for locating things and people across a company. IoT can help a clinic track the status of everything from wheelchairs to internal organ defibrillators to specialists in the medical services industry. A company in the transportation industry can convey quantity pursuit and the state of bundles and beds. for example, Maersk can use sensors to track the location and temperature of a plague transporting instrument.

Management and Automation

In a connected world, a company will have visibility into the condition of a device. In some cases, a company or client may also require a tool to be delivered to the executives. For example, a company can remotely initiate or transport a specific piece of pack or direct the temperature throughout AN setting controlled setting. Within the time unit, a client can use IoT to open their vehicle or start the washer. After establishing a presentation pattern, a method

can send alarms for irregularities and presumptively convey a programmed reaction. For example, if the brakes on a truck fail, the company will require the vehicle to be unobtainable and precisely arrange maintenance.

Price Savings

Several businesses will use IoT to save money. As opposed to opposition, live provides real execution information and instrumentation prosperity. Organizations, essentially trendy corporations, lose money when their instrumentation fails. With new contraption knowledge, IoT can help an organisation by reducing disappointment and allowing the company to provide organised support. Sensors could quantify things like driving behaviour and speed to reduce fuel costs and mileage on consumables. New low-cost metres in homes and businesses may provide information that assists people in recognising energy usage and opportunities for monetary investment.

Obtaining Started IOT

- **Framework what you'd Wish to Gain from Sensors**

Over succeeding 3 years, a greater part of the gadgets bought can have sensors and bunches of existing things is retrofitted with sensors. this can fabricate an enormous fluctuate of most recent data hotspots for people and frameworks to use to upgrade their lives and existing business measures. at spans a business setting, IT should diagram what assortments of information is gotten from these sensors and work with business pioneers to layout that business measures are improved with this new IoT data. for example, gadget data that features irregularities in instrumentation vibration is acclimated foresee and stay away from disappointment.

- **Construct Associate in Nursing IOT Organization and Security Establishment**

A few mechanical IoT arrangements have utilized restrictive organizations. Maybe than building exclusive organizations, IT should interface IoT gadgets with principles based informatics organizations. Partner in Nursing IP-based organization can work with organizations convey the exhibition, untrustworthiness and capacity that square measure expected to help world IoT organizations and associations with accomplice biological systems. for sure, a few organizations square measure focused on building security ways for cell phones and tablets, anyway this is frequently just 1 side of the new versatile world. The expansion of associated sensors and instrumentation gives new security issues. since it accepts IoT, it needs to ensure its designed protections into the appropriate response along with security strategies like equipment encoding, actual structure security and organization security for data on the way. Personality and confirmation structures additionally will must be refreshed to help "things" moreover as people.

- **Gather the Most Extreme Sum Data as Achievable**

Organizations that don't orchestrate thoroughly for IoT will be immersed with the sum and style of data that IoT can produce. though every gadget could exclusively fabricate atiny low amount of data, an association will be assortment data from thousands to adequate sensors. partnerships should assemble an information variety and examination procedure that upholds this new deluge of information during a climbable and cost successful way. gigantic data innovation, as Hadoop and NoSQL, will give firms the adaptability to slash hack gather, store and examine monster volumes of different IoT data. an association should gather any data that is pertinent to existing cycles. In the event that achievable and cost-proficient, an association should conjointly gather additional data that may adjust the business to answer new inquiries inside what's to come.

- **Audit the Measurements and Size of IOT Providers**

IoT could be a modern scene with differed classes and heaps of merchants at spans each class. The four principle classes of Associate in Nursing IoT answer are: a sensor(s) and radio(s) that typically sits inside the machine, a M2M gadget the board stage, an answer conveyance stage and applications that change IoT gadgets to report or follow up on data. though their square measure a few merchants, no single dealer offers a whole answer while not structure associations. As a firm starts its IoT journey, IT and line of business heads should assemble a cross-practical group to

gauge key accomplices. The group should gauge the financial situation of the merchants, business information, associations and expansiveness of contributions.

2D Layouts of Model

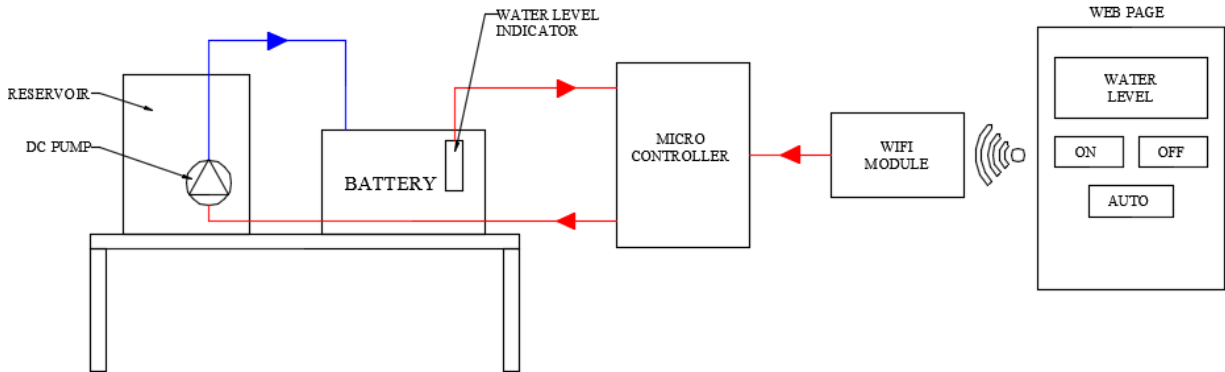

Fig. 2. 2D Layouts of Model

Conclusion

This paper discusses the planning and advancement of IOT recognition of water abuse. This well-organized framework houses a limited inventory of Sensors such as voltmeters. This device was an interaction Associate in Nursing that gathered information from the generator. Associate in Nursing sent the knowledge to the administrator via the internet or any Wi-Fi employee to the individual's non-public versatile quantities in such cases they'll be capable of knowing the extent of water and adding water it has to want for it on time. This device was of low esteem and had a reasonable price as a yield, additional strength, a short lifespan, and numerous alternatives. In the future, we'd like to produce Associate in Nursing programmed advancement of the batteries in such a way that there's a chance of obtaining a low volume of water, Adding as much as possible by swinging away it once the individual supply overabundance quantity there to.

References

- [1] Atzori, L.; Iera, A.; Morabito, G. Understanding net of Things: Definition, possibilities, and get-together of people occupation of a quick progressing perspective. *AdHoc Netw.*, 2017, 56, 122–140.
- [2] Szumanowski and Y. Chang, "Battery the board system maintained battery nonlinear parts illustrating," *IEEE Trans. Veh. Technol.*, 2008., vol. 57, no. 3, pp. 1425–1432, May 2008.
- [3] Irsyad N. H., Edi Leksono, M. Iqbal, FX Nugroho S., Nugraha, Dedy Kurniadi, Brian Yulianto, Development of Battery Management System for Cell acknowledgment and Protection, *IEEE Int. Conf. on Elect. arranging and advancement*, pp. 24-25 Nov. 2014.
- [4] C. Hommalai and S. Khomfoi "Battery acknowledgment System by discovery Dead Battery Cells", *International Journal of Science and assessment*, Vol.1, pp. 5-15, 2011.
- [5] Y. Li, L. Zhen, "Battery Management System", 2010 *International Conference on activity Technology and Mechatronics Automation*, pp. 739-741, 2010.
- [6] J. Cao, N. Schofield, and A. Emadi, "Battery bargain systems: an extreme review," *In 2008 IEEE Vehicle Power and Propulsion Conference, VPPC 2008*, 2008, pp. 1–6.
- [7] J. A. Asumadu, M. Haque, H. Vogel, and C. Willards, "Precision Battery Management System," *In 2005 IEEE Instrumentation and live Technology Conference Proceedings*, 2005, vol., no. May, pp. 17–19.
- [8] B. Pattipati, K. Pattipati, J. P. Christopherson, S. M. Namburu, D. V. Prokhorov, and L. Q. L. Qiao,

"Vehicle battery the board systems," *2008 Ieee machine check con*, no. September, pp.8–11, Sep.2008.

- [9] J. Chatzakis, K. Kalaitzakis, N. C. Voulgaris and S. N. Lunacies, "Arranging a replacement summarized battery the board system", *IEEE Trans. Ind. Electron.* Vol. 50, No. 5, pp. 990 - 999, 2003.